

Stove for 8m² and 10m² Scheffler

Reflectors :

This manual describes a stove for 30° latitude. It can be used for all installations between 25° and 30° latitude, irrespective of north or south hemisphere. If your location is not between 25° and 30° latitude you have to substitute the measurements in the manual by those given for your range of latitude on the website. The procedure for construction remains the same. We recommend to download the scale drawings (1:1) and to print them, too.

Followingly the stove is called „cooking place“.

Photos are available for download as separate file.

1) Material :	3
LIST.....	3
Part 1 : frame for cooking place (square pipe 25X25X2)	4
Part 2 : frame for cooking place (square pipe 25X25X2)	5
part 3 : frame for cooking place (square pipe 25X25X2).....	6
part 4 : frame for cooking place (square pipe 25X25X2).....	7
Part 5 : frame for cooking place (square pipe 25X25X2)	8
Part 6 : frame for cooking place (square pipe 25X25X2)	9
Part 7 : frame for cooking place (square pipe 25X25X2)	10
part 8 : frame for cooking place (square rod 12X12).....	11
part 9 : frame for cooking place (square rod 10X10).....	12
part 10 : frame for cooking place (square pipe 25X25X2).....	13
part 11 : frame for cooking place (square rod 10X10).....	14
part 12 : frame for cooking place (round bar 10mm diameter)	15
part 13 : top hinge (flat bar 25X6).....	16
part 14 : bottom hinge (flat bar 25X6).....	17
part 15 : frame for door (square rod 10X10)	18
part 16 : frame for door (square rod 10X10)	19
part 17 : frame for door (square rod 10X10)	20
part 18 : door handle (round bar, 8mm diameter)	21
part 19 : bolt M8.....	22
part 20 : Central support of secondary reflector (galvanized sheet 0.8mm)	22
part 21 : lateral support of secondary reflector (galvanized sheet 0.8mm)	23
part 22 : Coversheet for side (galvanized sheet 0.8 mm)	24
part 23 : Coversheet for back (galvanized sheet 0.8 mm)	25
part 24 : Coversheet for top (galvanized sheet 0.8 mm).....	26
part 25 : sheet for door (iron sheet 1.8 mm).....	28
part 26 : spring.....	29
part 27 : nut (M8)	29
part 28 : Stiffener for secondary reflector (flat bar 25X3)	30
Part 29 : Secondary reflector sheets (Aluminium sheet 1 mm).....	31

2) Procedure of Assembly.....	32
Step 1	32
Step 2	33
Step 3	34
Step 4	35
Step 5	36
Step 6	38
Step 7	39
Step 8	41
Step 9	42
Step 10	43
Step 11	44
Step 12	46
Step 13	47
Step 14	48
Step 15	49
Step 16	51
Step 17	52
Step 18	53
Step 19	55
Step 20	56
Step 21	58
Step 22	59
Step 23	60
Step 24	61
step 25	63
step 26	64
step 27	66
step 28	67
step 29	69
step 30	70

1) Material :

LIST

Number of Part	Name	Profile	Quantity
	1 Frame for cooking place	square pipe 25X25X2	2
	2 Frame for cooking place	square pipe 25X25X2	2
	3 Frame for cooking place	square pipe 25X25X2	2
	4 Frame for cooking place	square pipe 25X25X2	2
	5 Frame for cooking place	square pipe 25X25X2	3
	6 Frame for cooking place	square pipe 25X25X2	1
	7 Frame for cooking place	square pipe 25X25X2	1
	8 Frame for cooking place	round bar 12X12	1
	9 Frame for cooking place	round bar 10X10	2
	10 Frame for cooking place	round bar 25X25X2	2
	11 Frame for cooking place	round bar 10X10	1
	12 Support for pot	round bar D=10	2
	13 Top hinge	flat bar 25X6	2
	14 Bottom hinge	flat bar 25X6	2
	15 Door frame	square rod 10X10	4
	16 Door frame	square rod 10X10	4
	17 Door frame	square rod 10X10	4
	18 Door handle	round bar D=8	2
	19 bolt	bolt M8	2
	20 Central support of secondary refelctor	galvanized sheet 0.8mm	1
	21 Lateral support of secondary refelctor	galvanized sheet 0.8mm	2
	22 Coversheet for side	galvanized sheet 0.8mm	2
	23 Coversheet for back	galvanized sheet 0.8mm	1
	24 Coversheet for top	galvanized sheet 0.8mm	1
	25 Sheet for door	Iron sheet 1.8mm	2
	26 spring	spring	2
	27 nut	nut (M8)	4
	28 Stiffener for secondary reflector	Flat bar 25X3	6
	29 Secondary reflector sheets	Aluminiumsheet 1mm	6

Part 1 : frame for cooking place (square pipe 25X25X2)

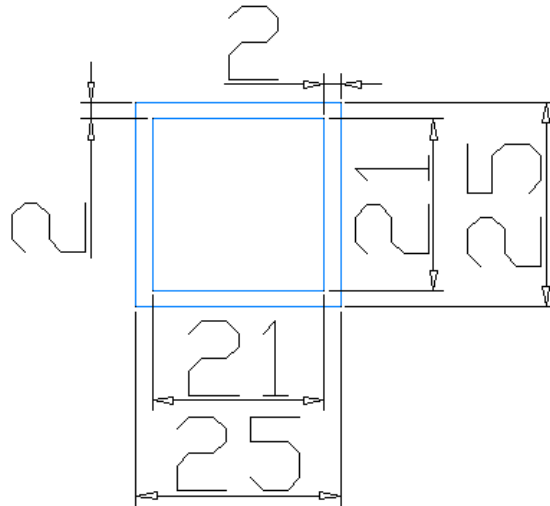
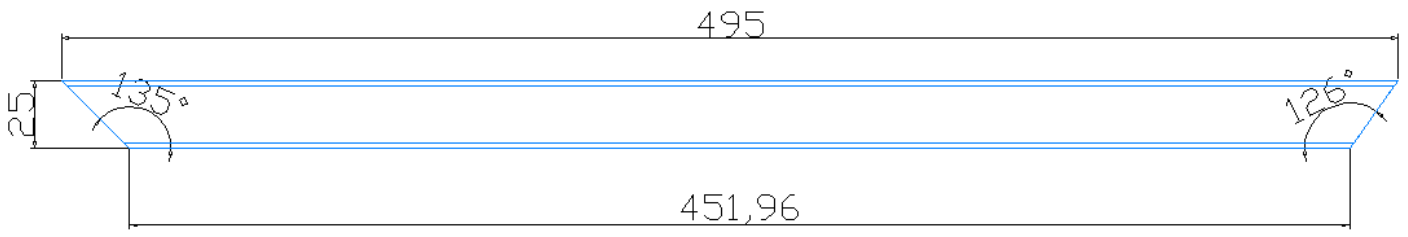

①

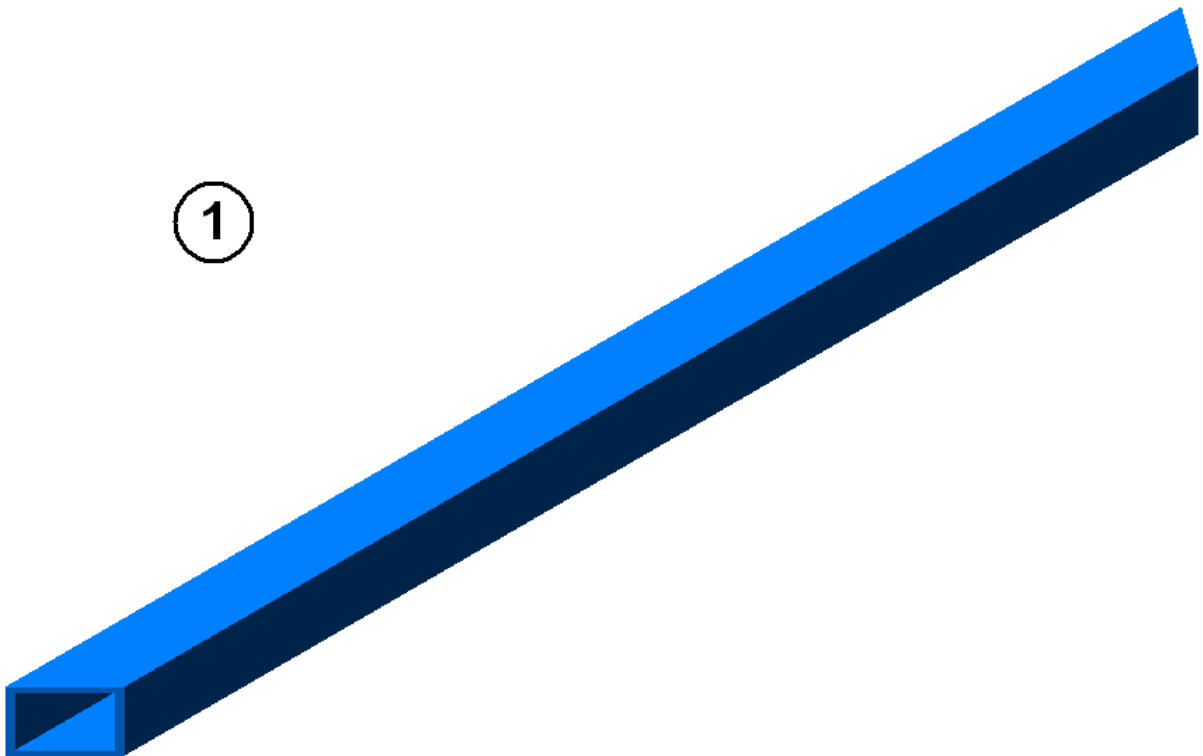

Part 2 : frame for cooking place (square pipe 25X25X2)

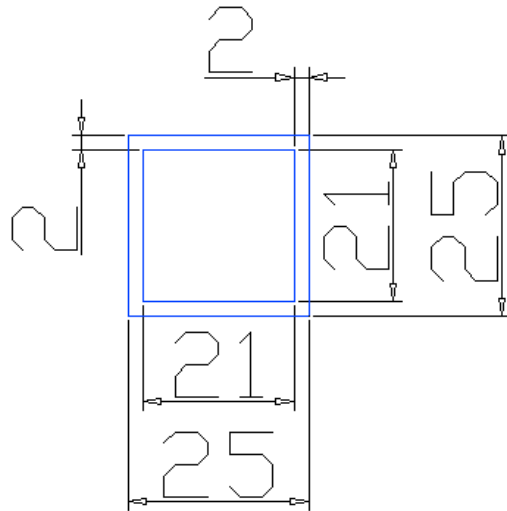
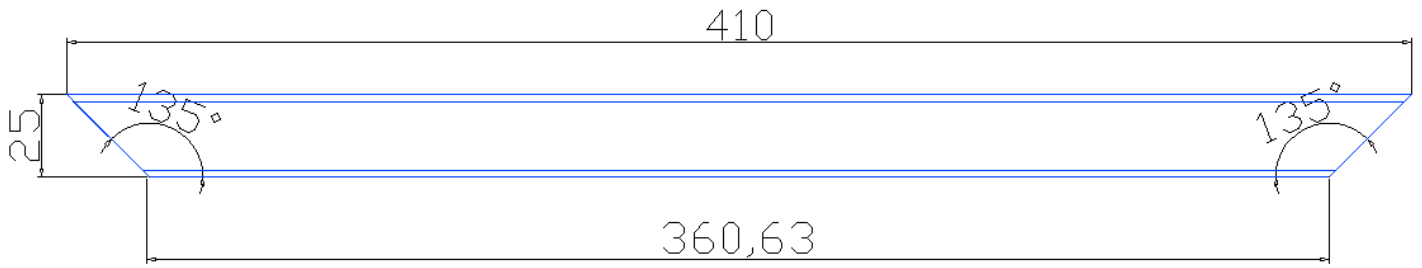

2

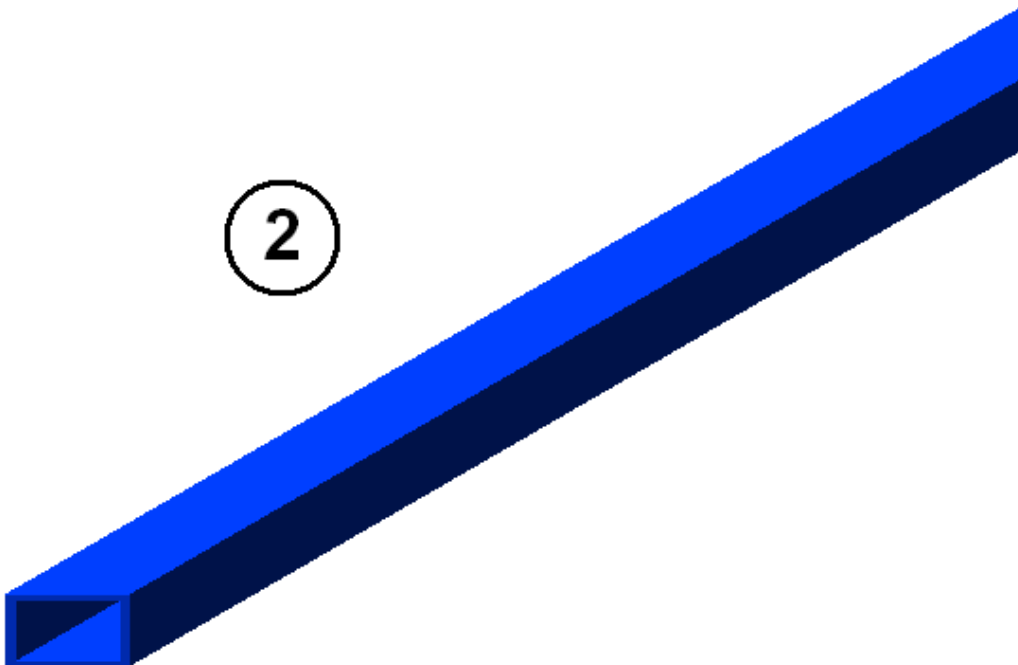

part 3 : frame for cooking place (square pipe 25X25X2)

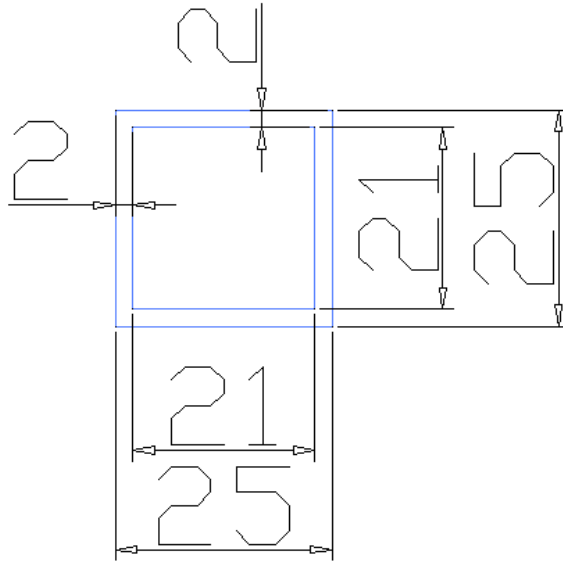
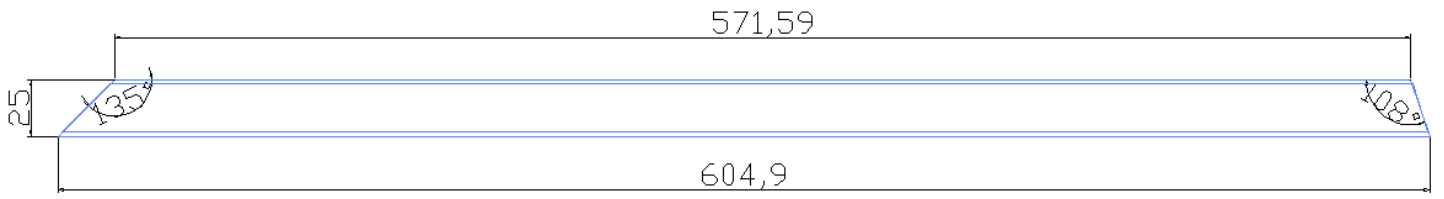

3

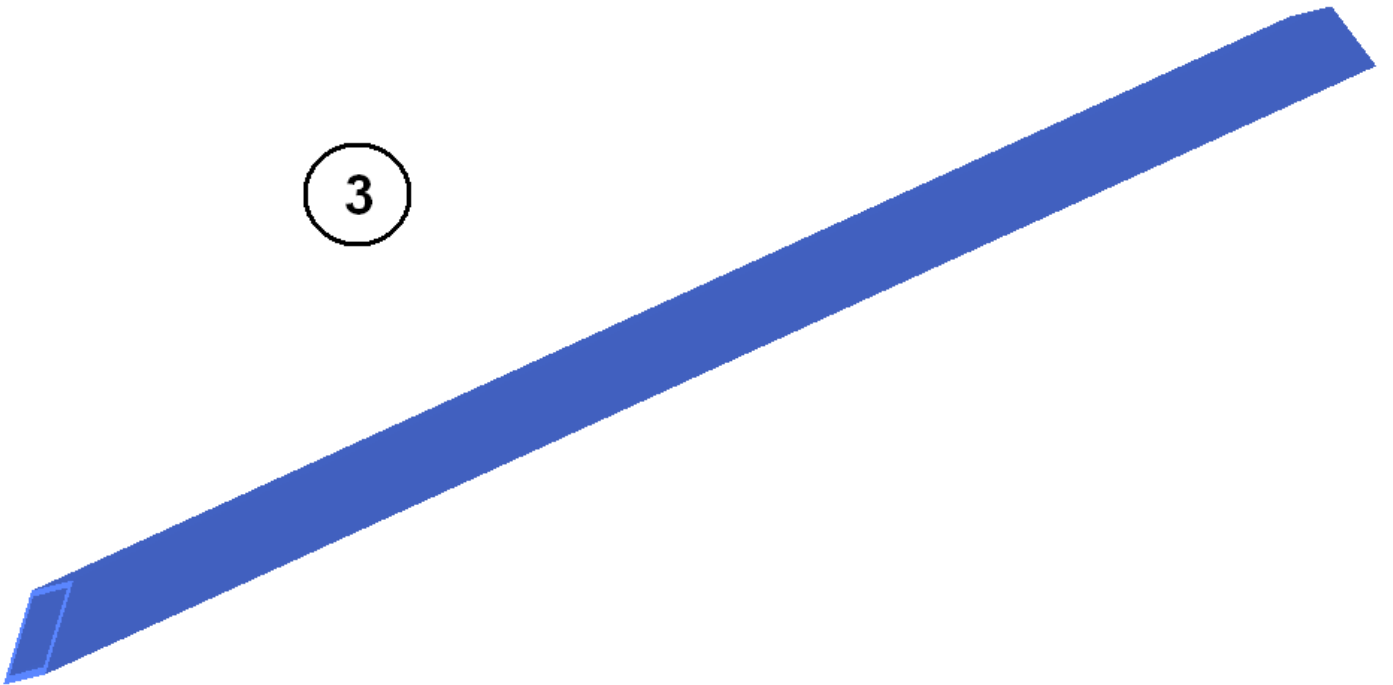

part 4 : frame for cooking place (square pipe 25X25X2)

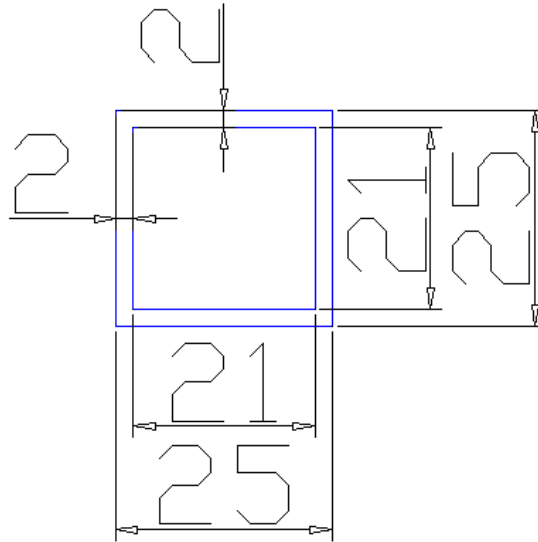
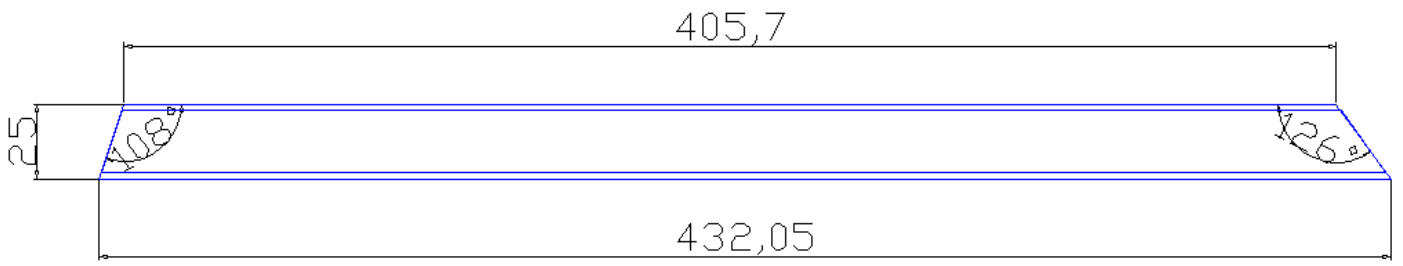

4

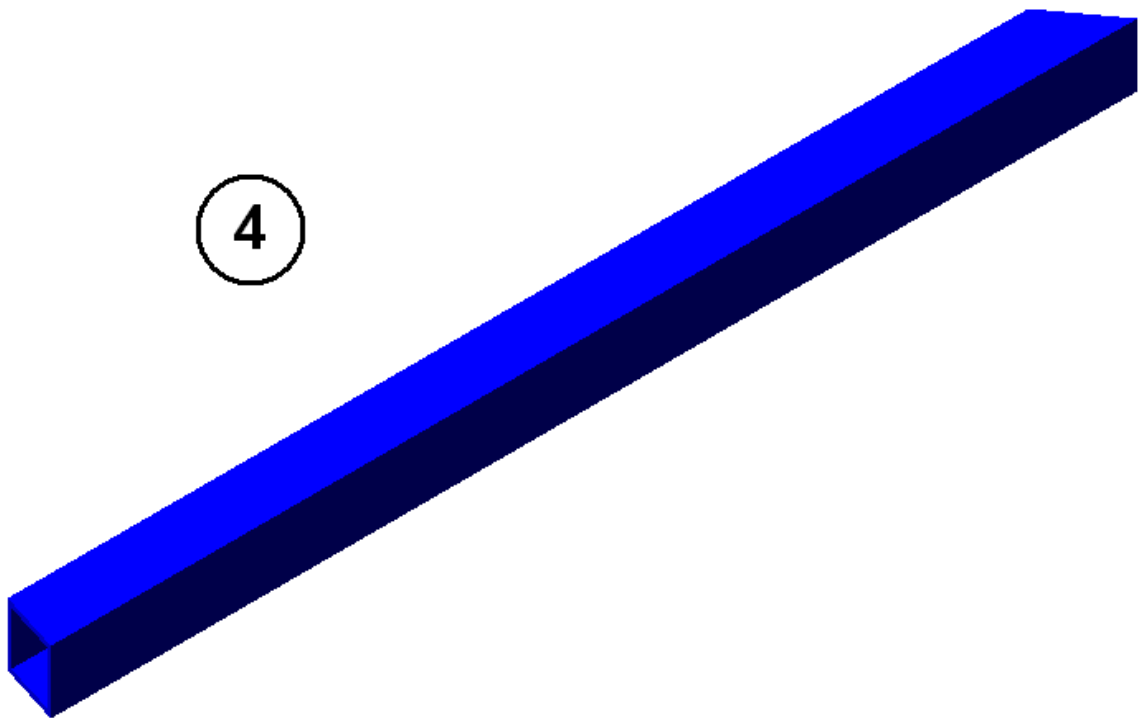

Part 5 : frame for cooking place (square pipe 25X25X2)

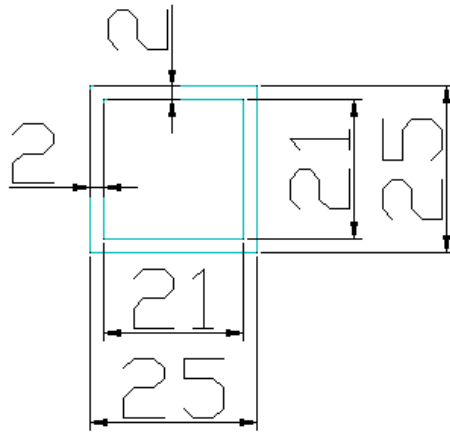
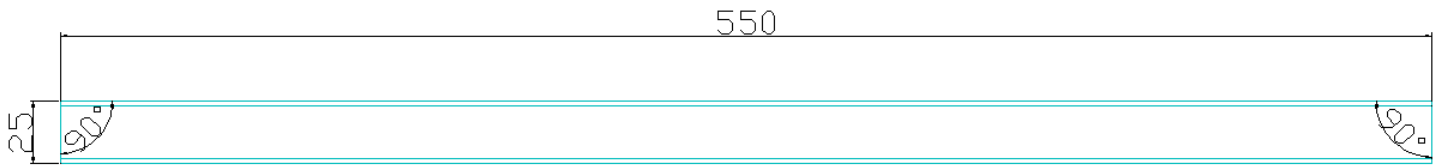

5



Part 6 : frame for cooking place (square pipe 25X25X2)

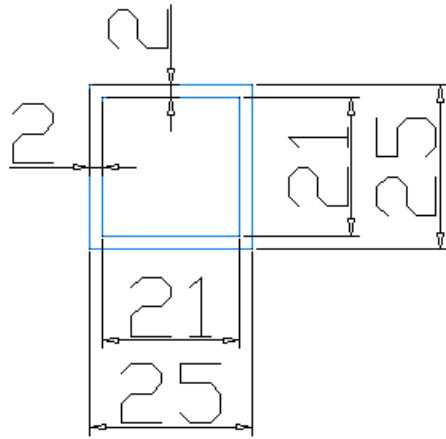
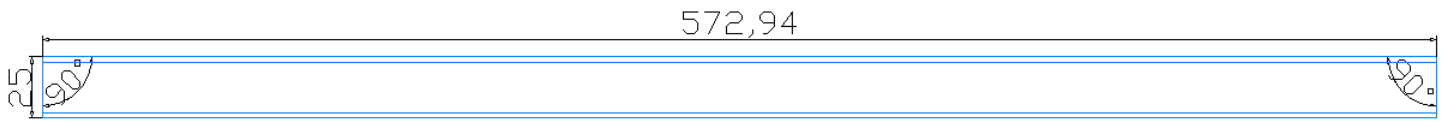

6

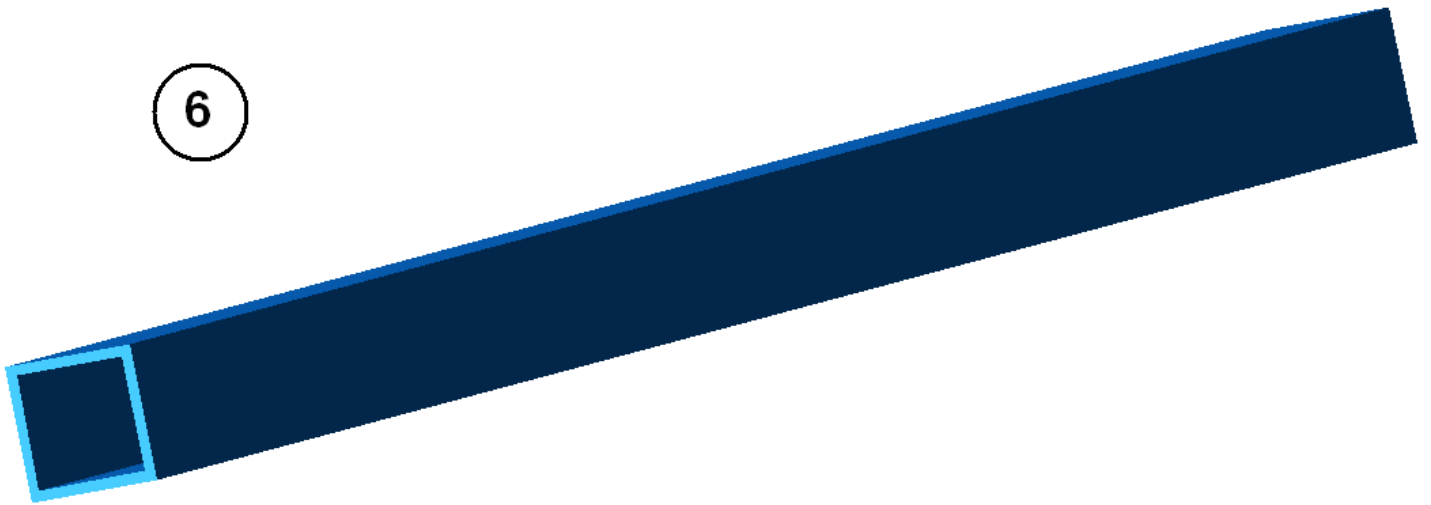

Part 7 : frame for cooking place (square pipe 25X25X2)

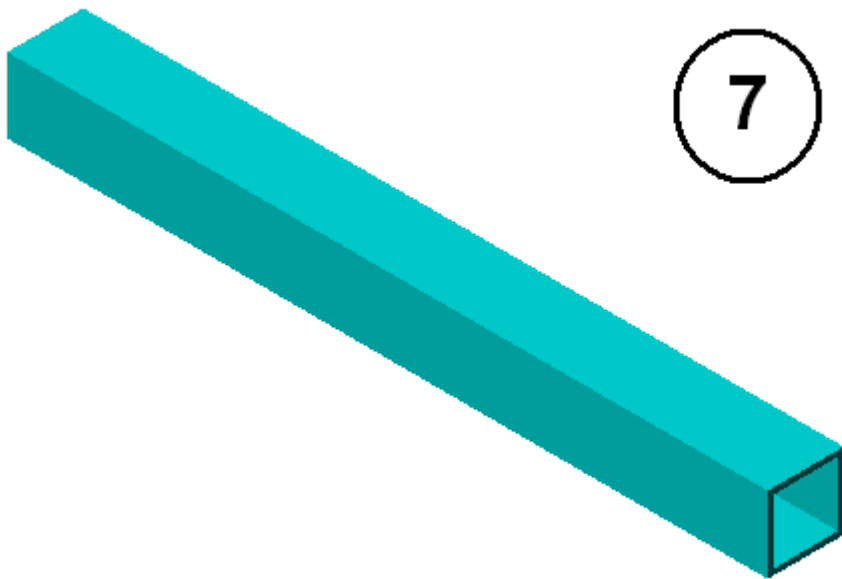
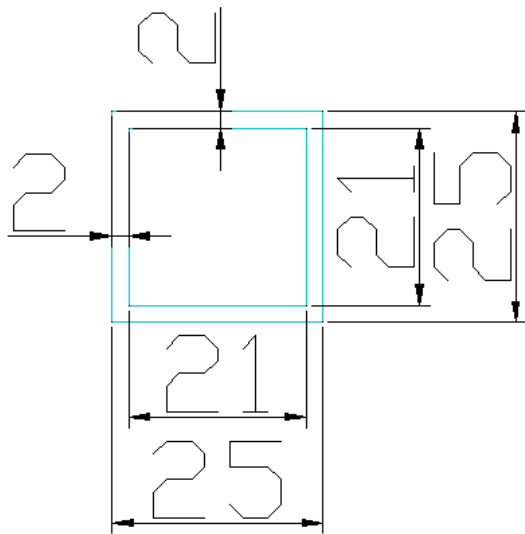
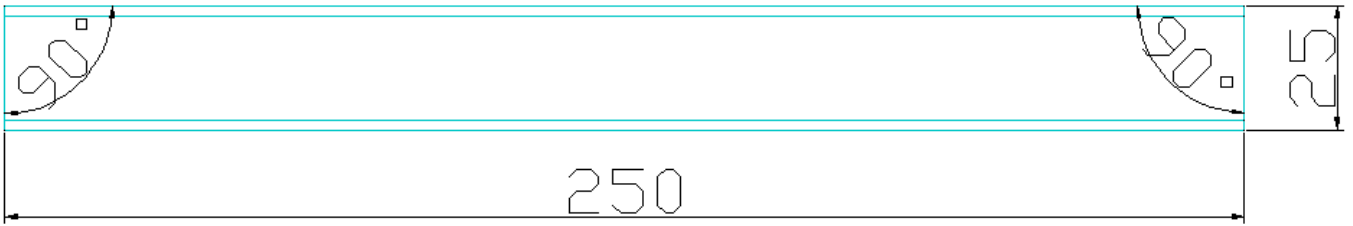

part 8 : frame for cooking place (square rod 12X12)

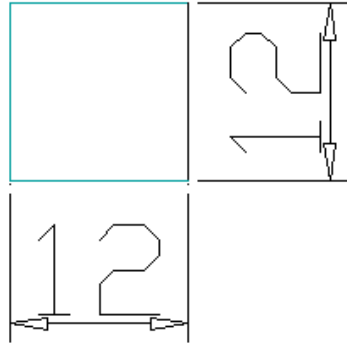
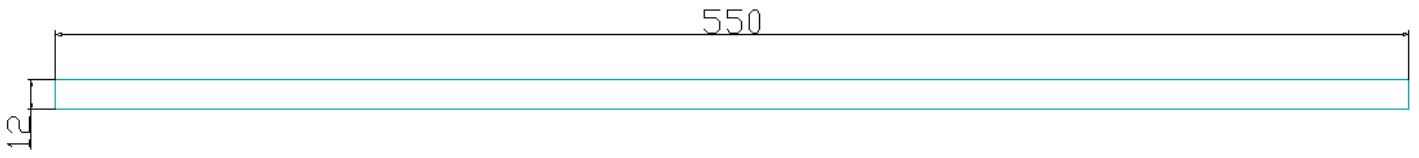

8

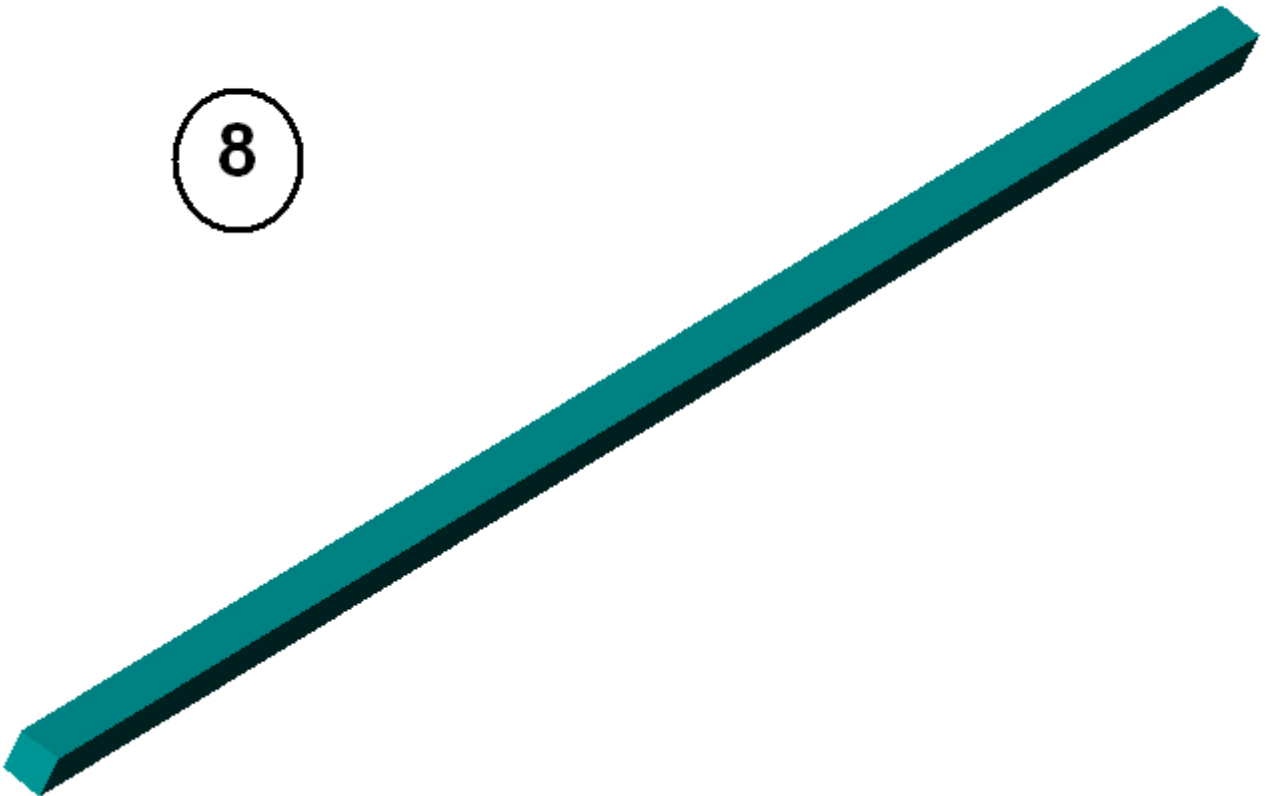

part 9 : frame for cooking place (square rod 10X10)

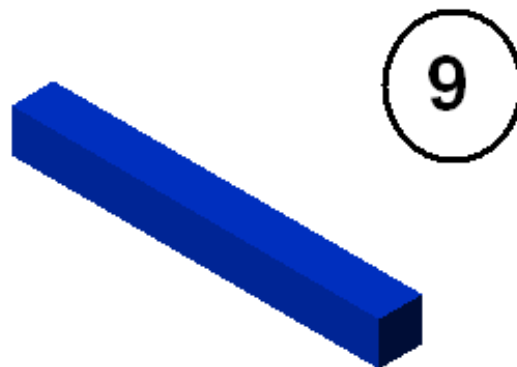
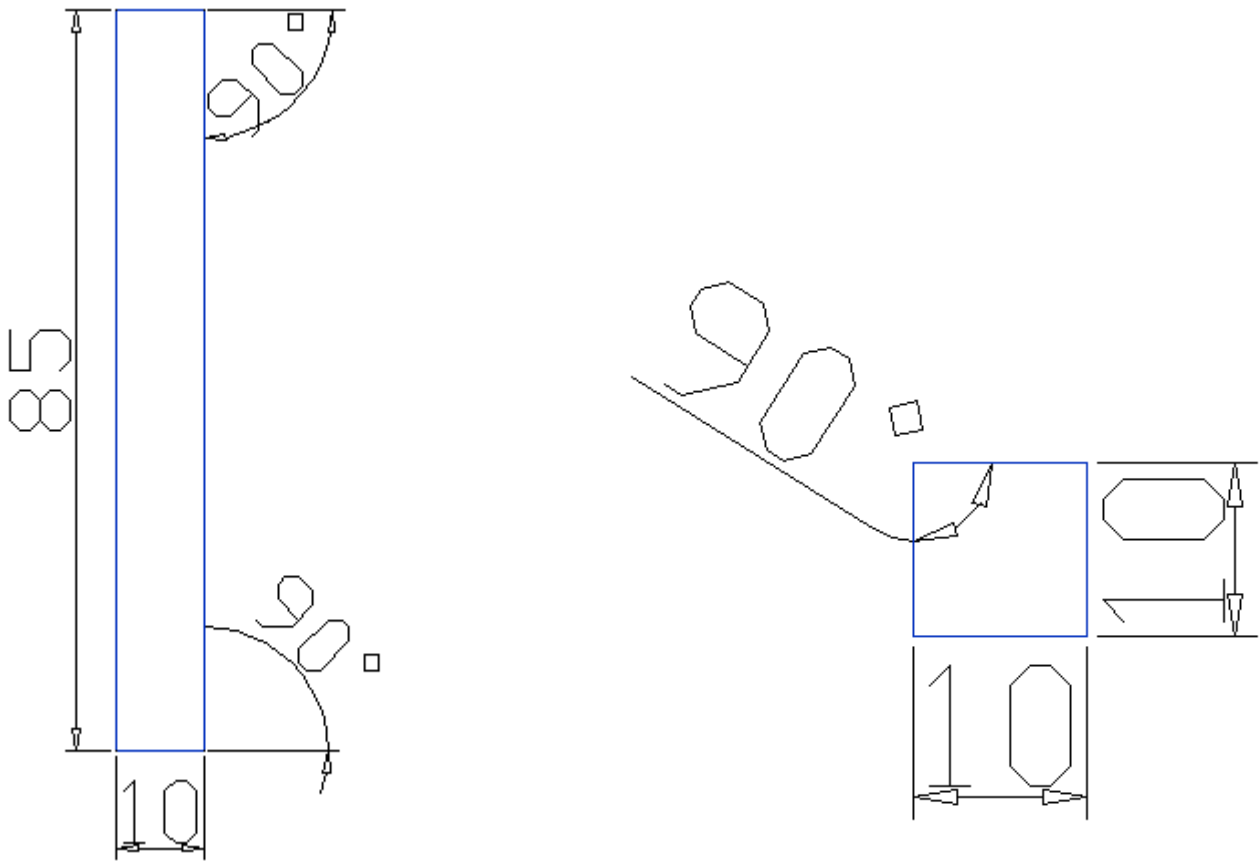

part 10 : frame for cooking place (square pipe 25X25X2)

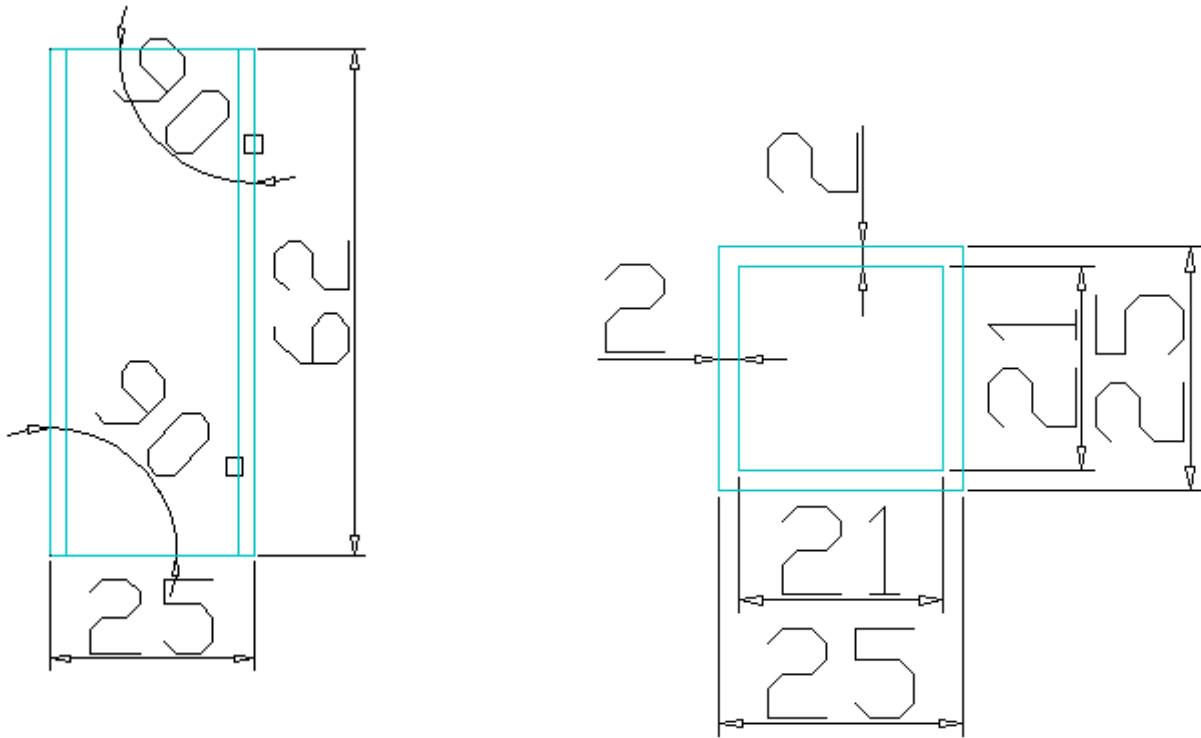

part 11 : frame for cooking place (square rod 10X10)

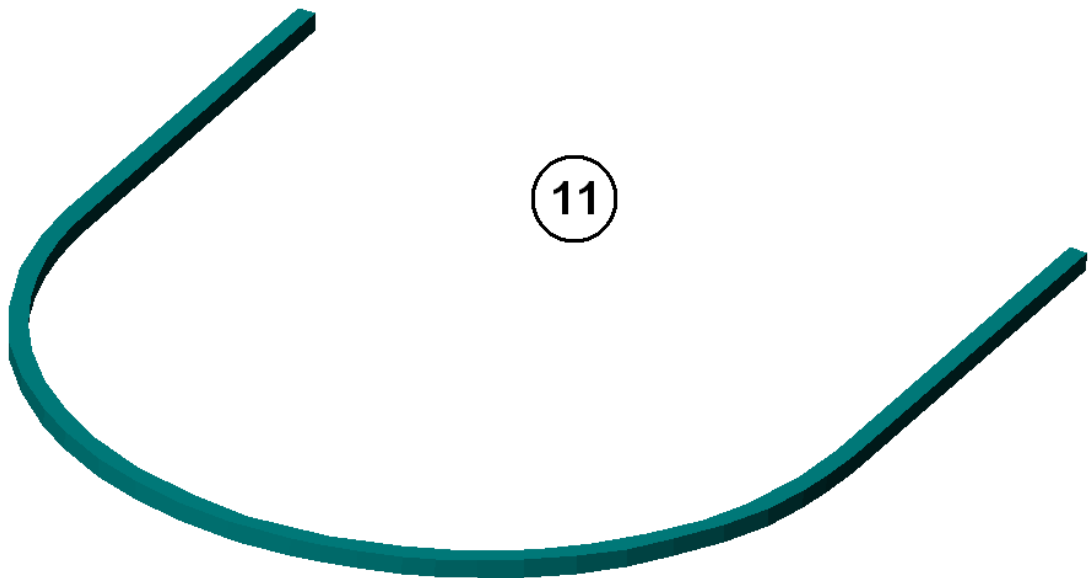
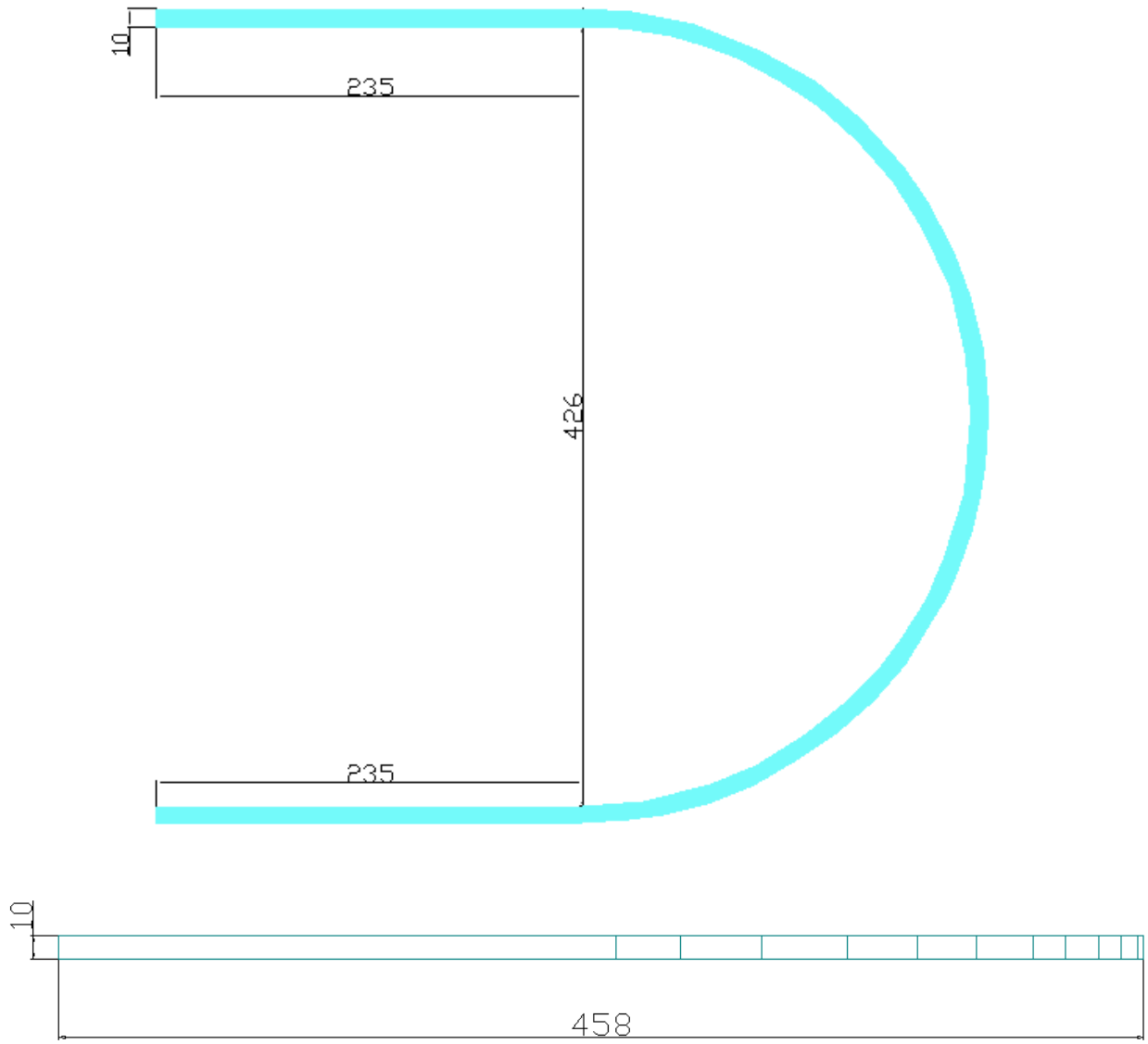

part 12 : frame for cooking place (round bar 10mm diameter)

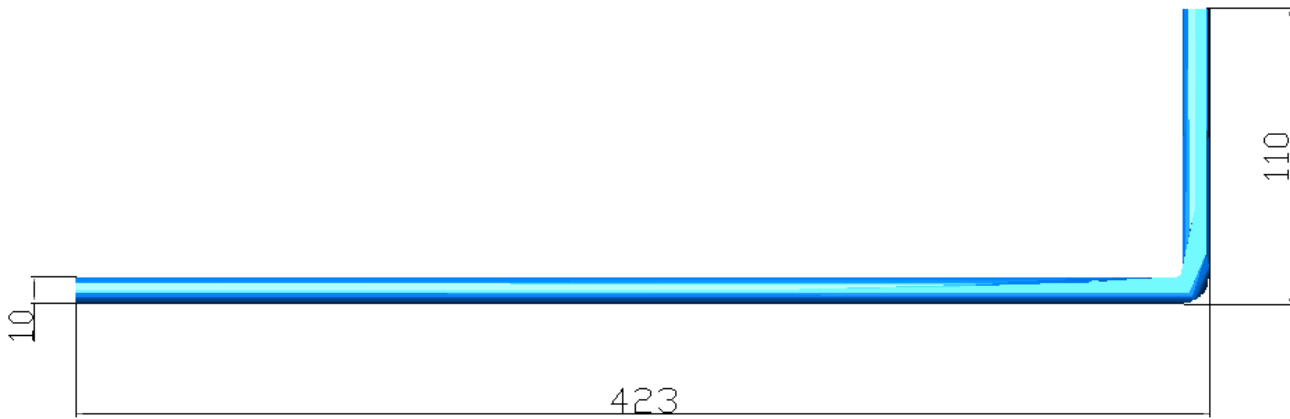

12



part 13 : top hinge (flat bar 25X6)

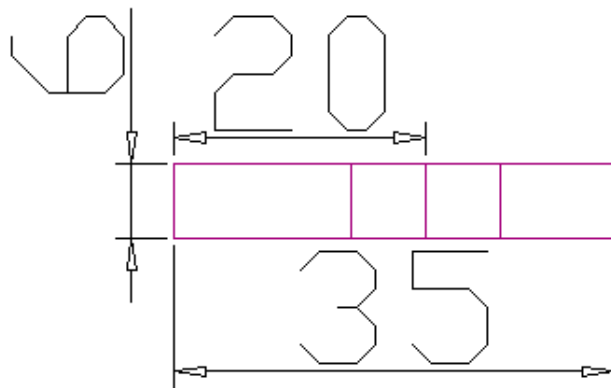
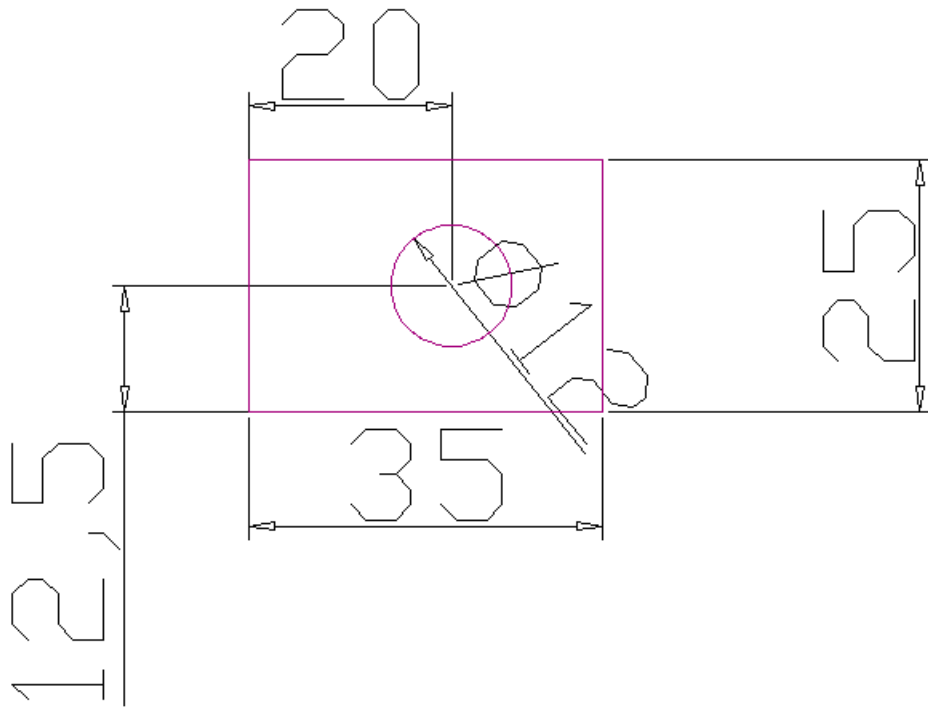

13

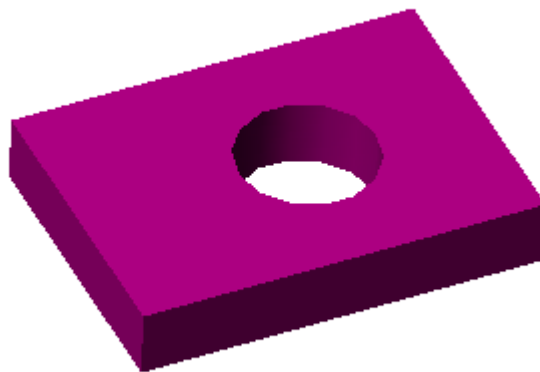

part 14 : bottom hinge (flat bar 25X6)

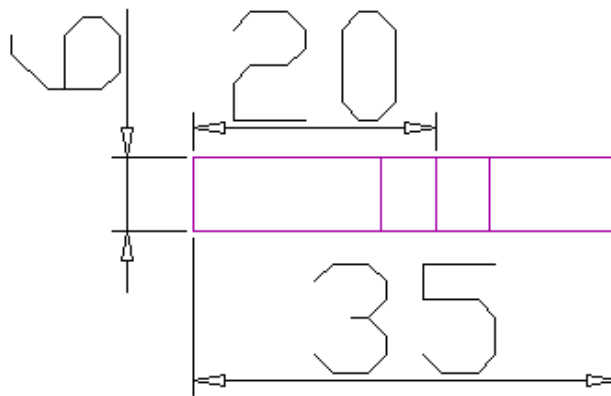
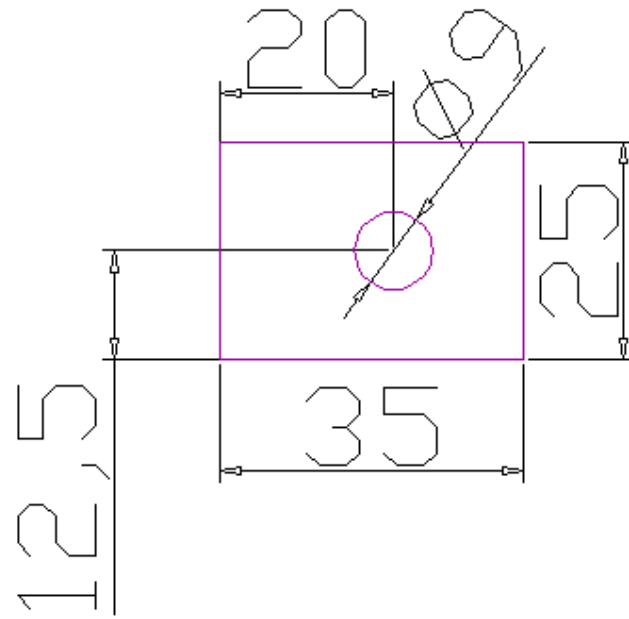

14

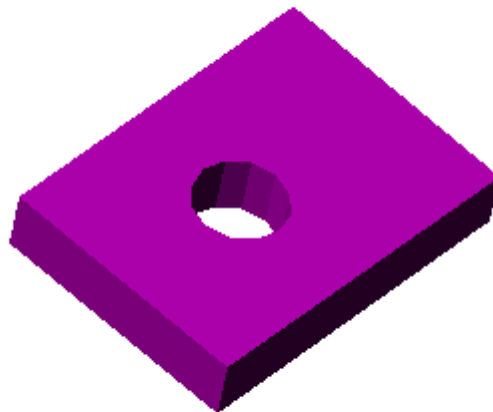

part 15 : frame for door (square rod 10X10)

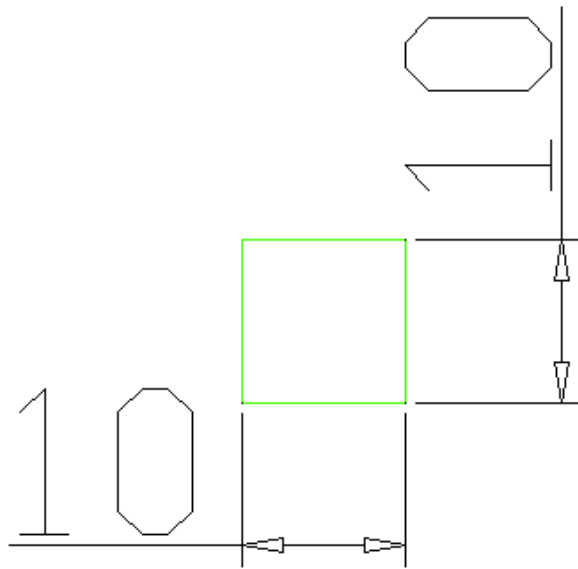
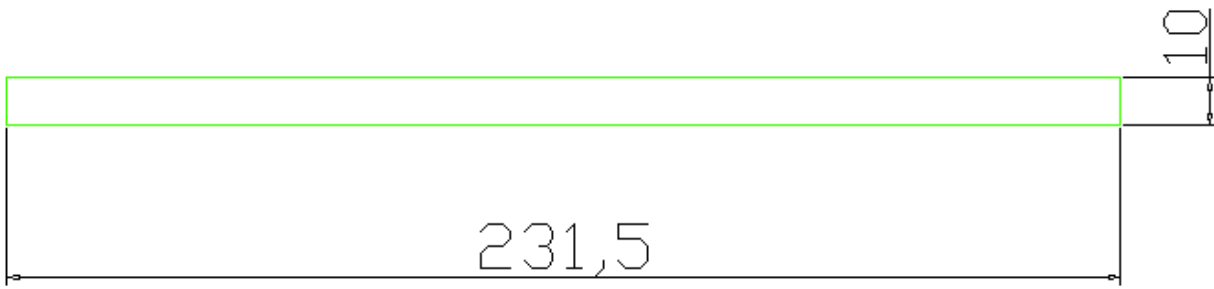

15

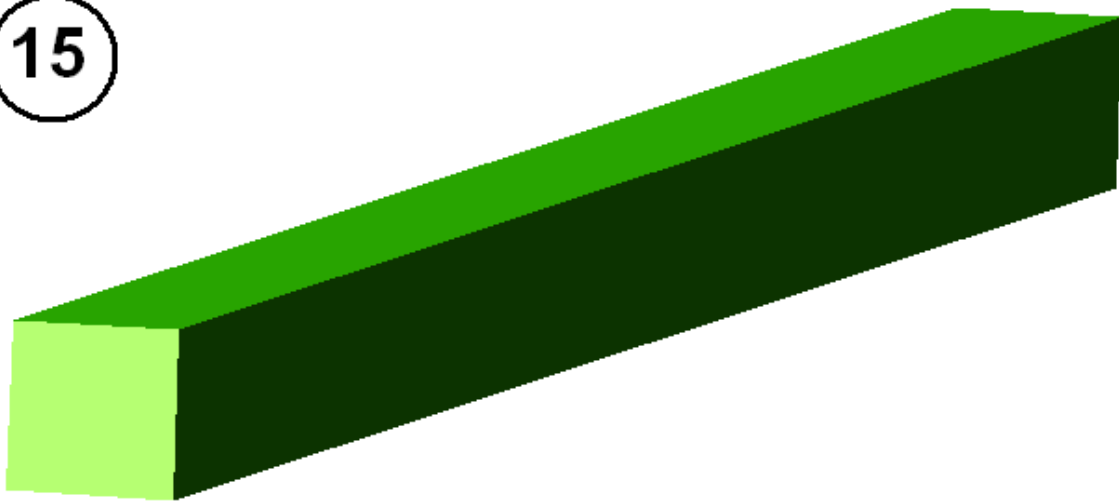

part 16 : frame for door (square rod 10X10)

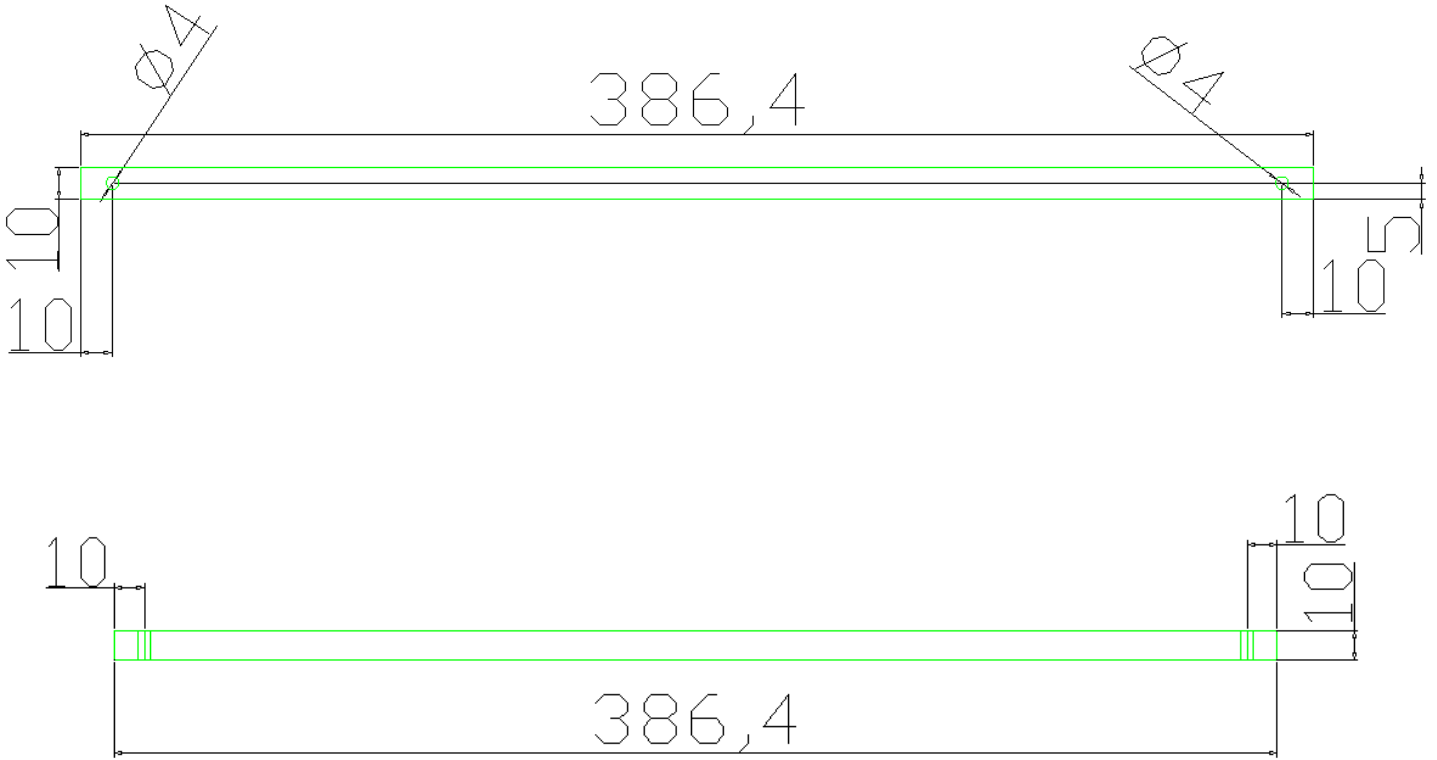

16

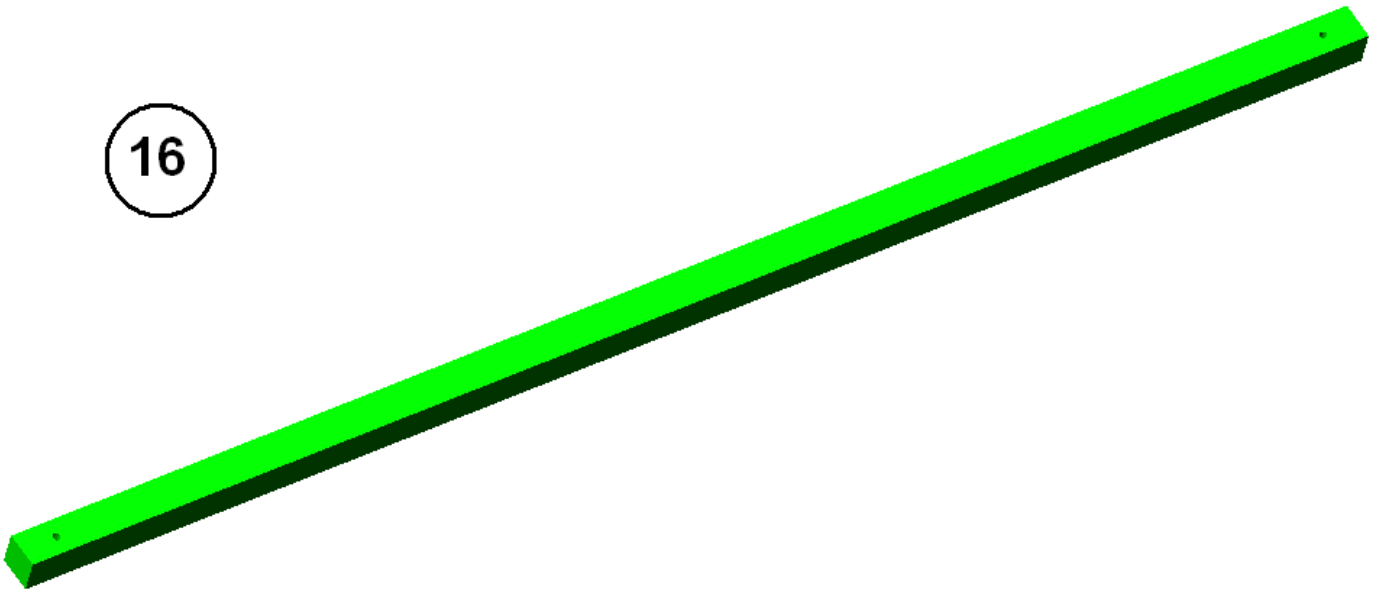

part 17 : frame for door (square rod 10X10)

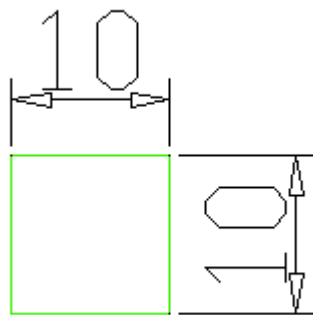
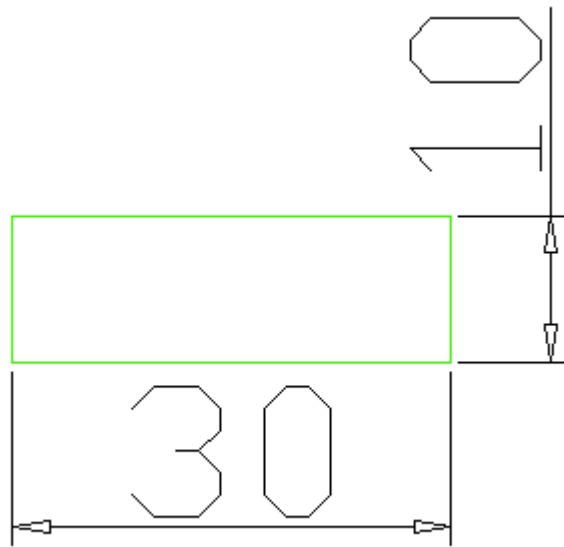

17

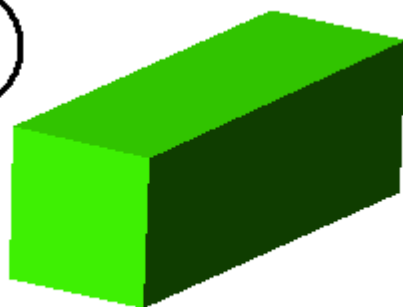

part 18 : door handle (round bar, 8mm diameter)

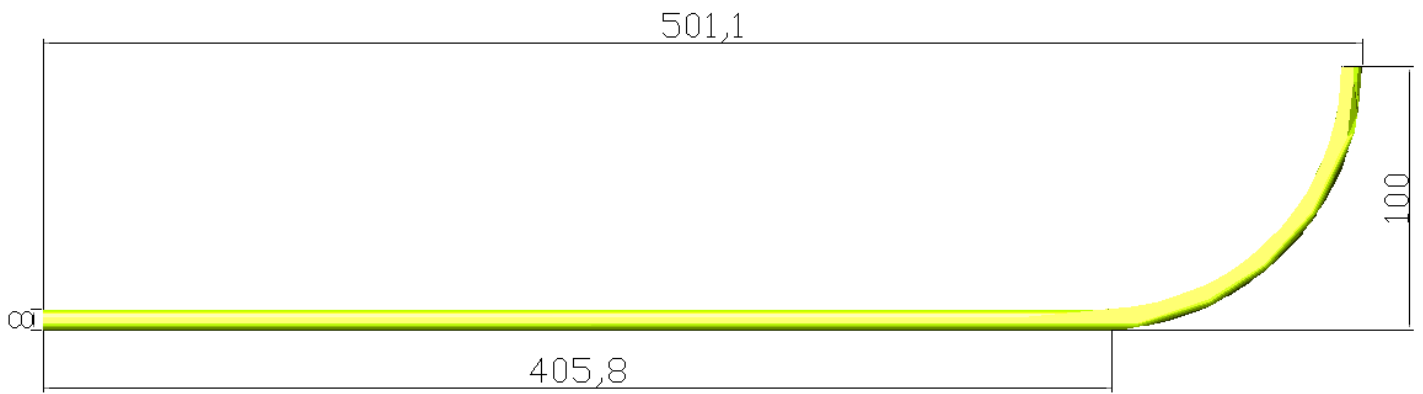

18

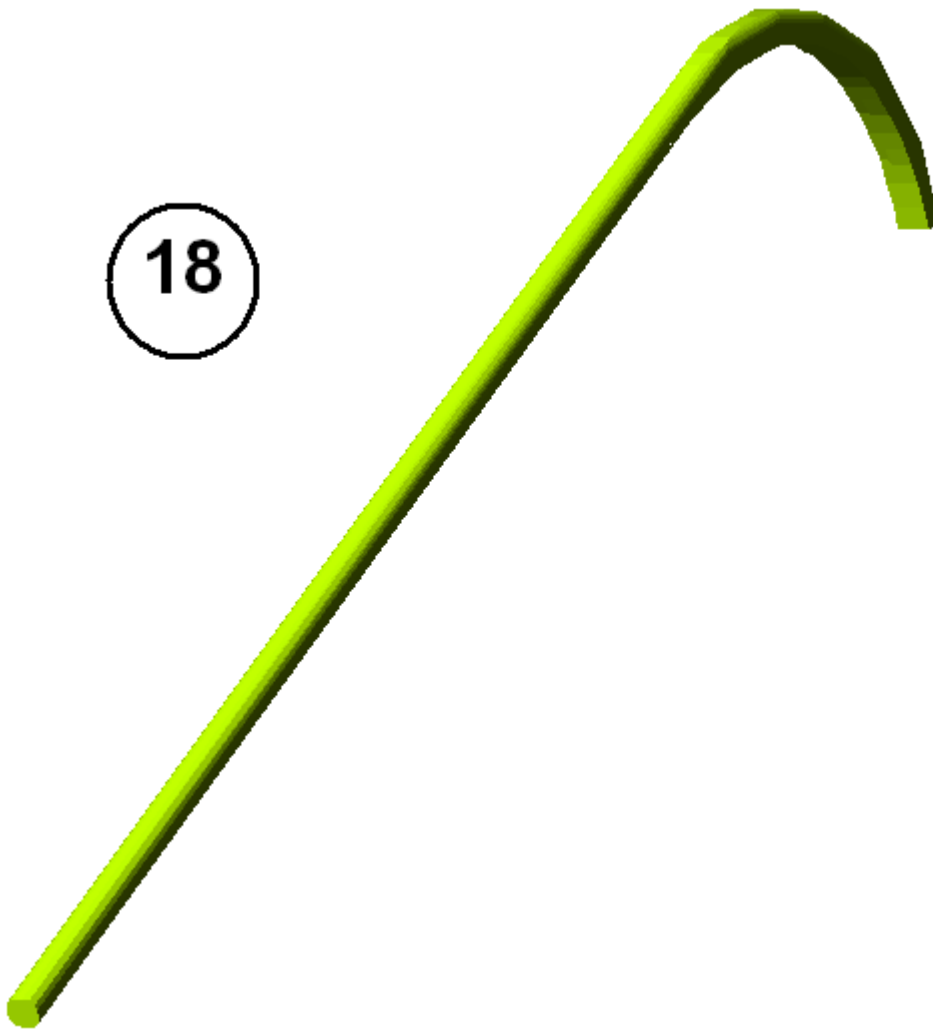

part 19 : bolt M8

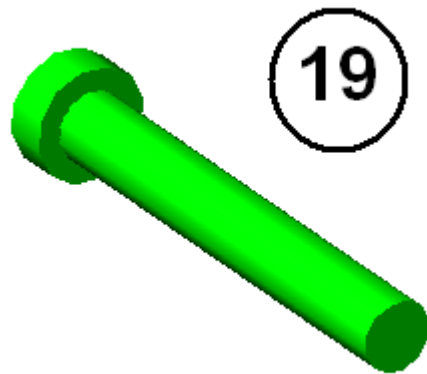

part 20 : Central support of secondary refelctor (galvanized sheet 0.8mm)

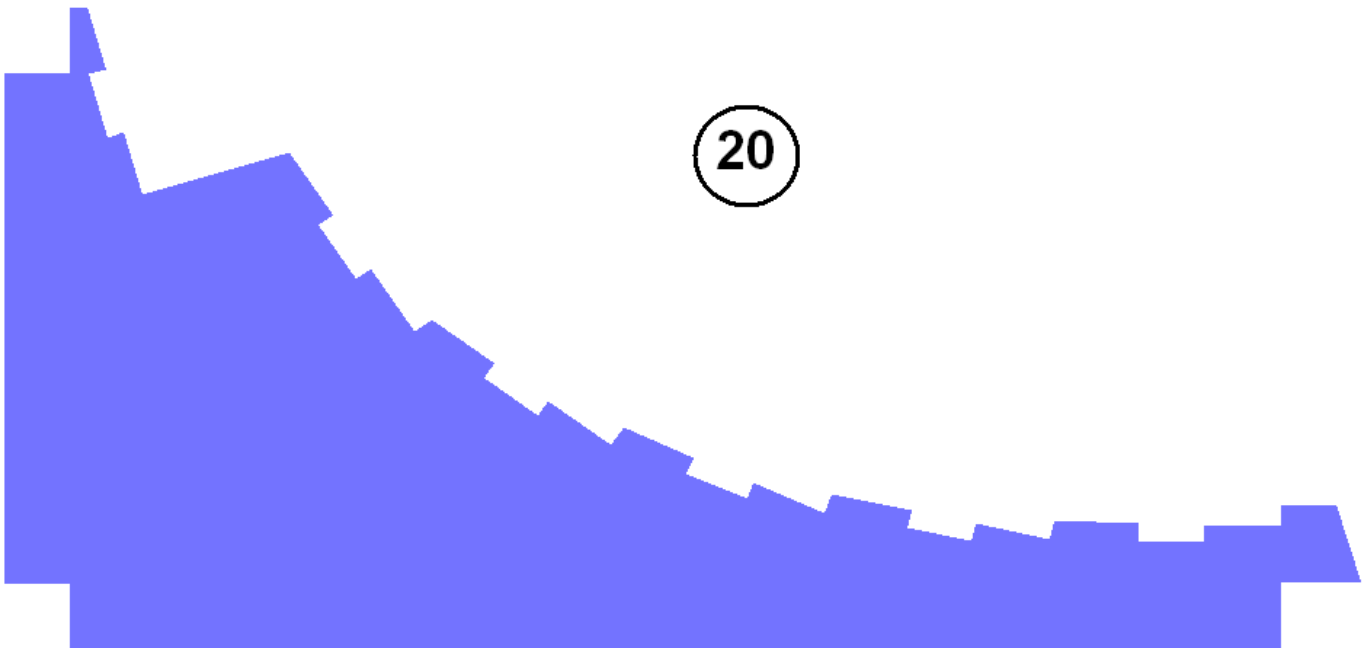

part 21 : lateral support of secondary reflector (galvanized sheet 0.8mm)

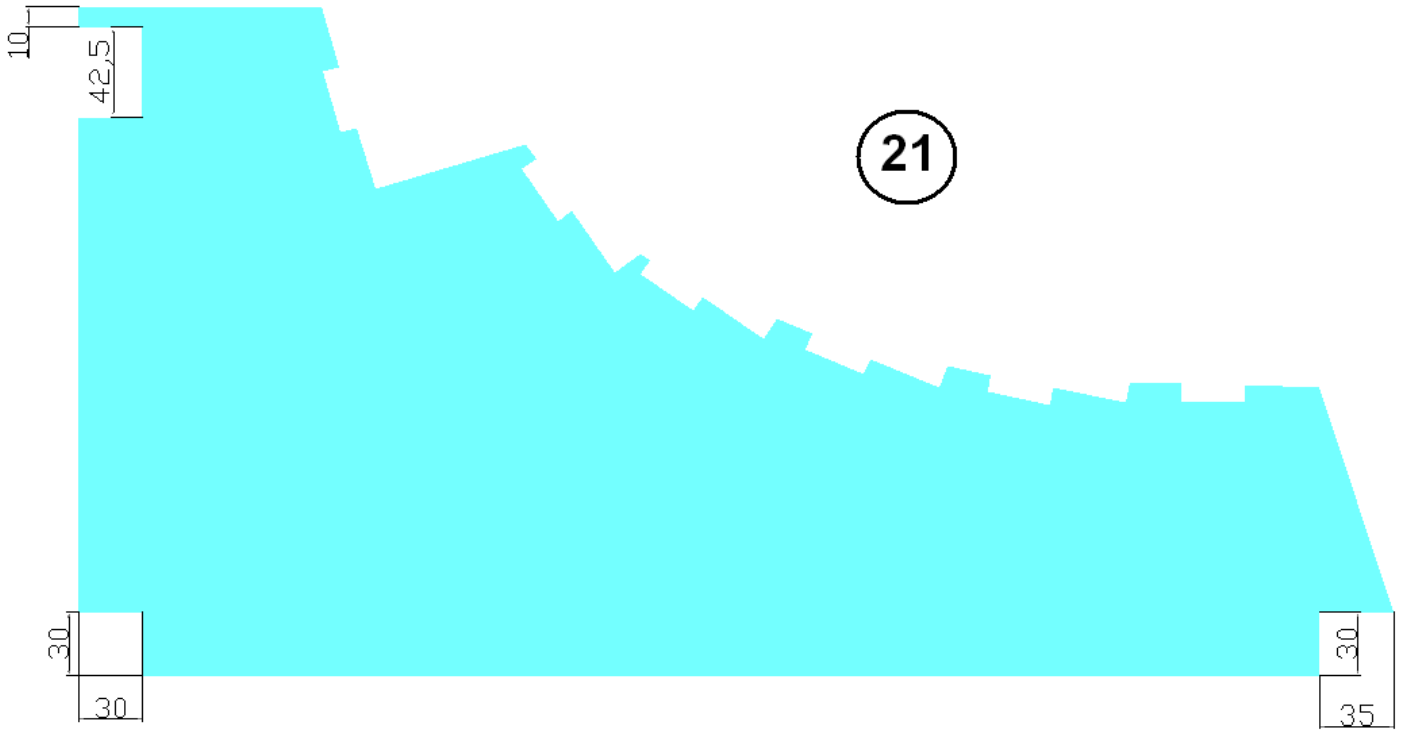

part 22 : Coversheet for side (galvanized sheet 0.8 mm)

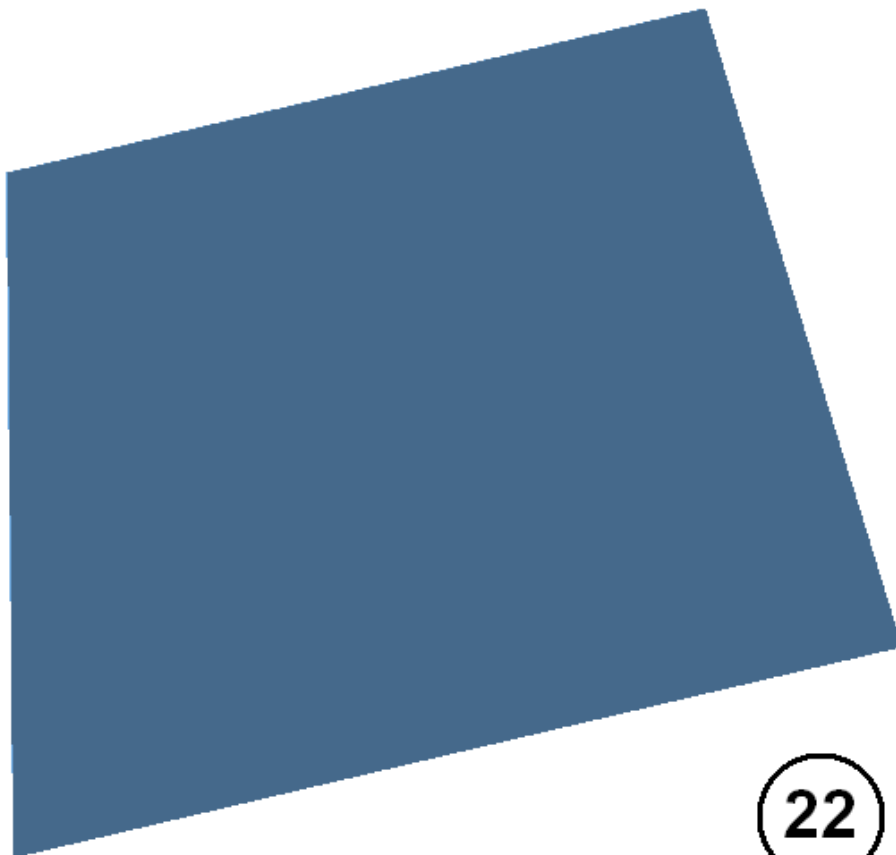
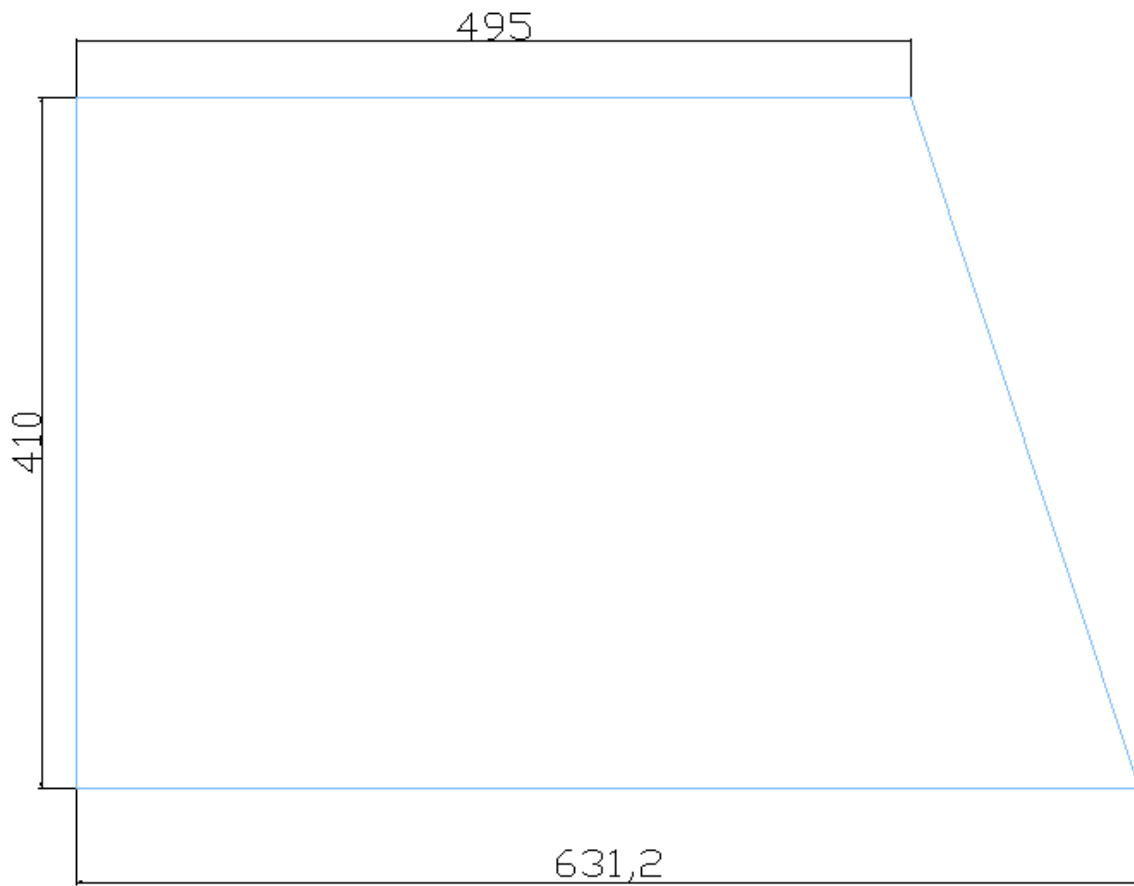

22

part 23 : Coversheet for back (galvanized sheet 0.8 mm)

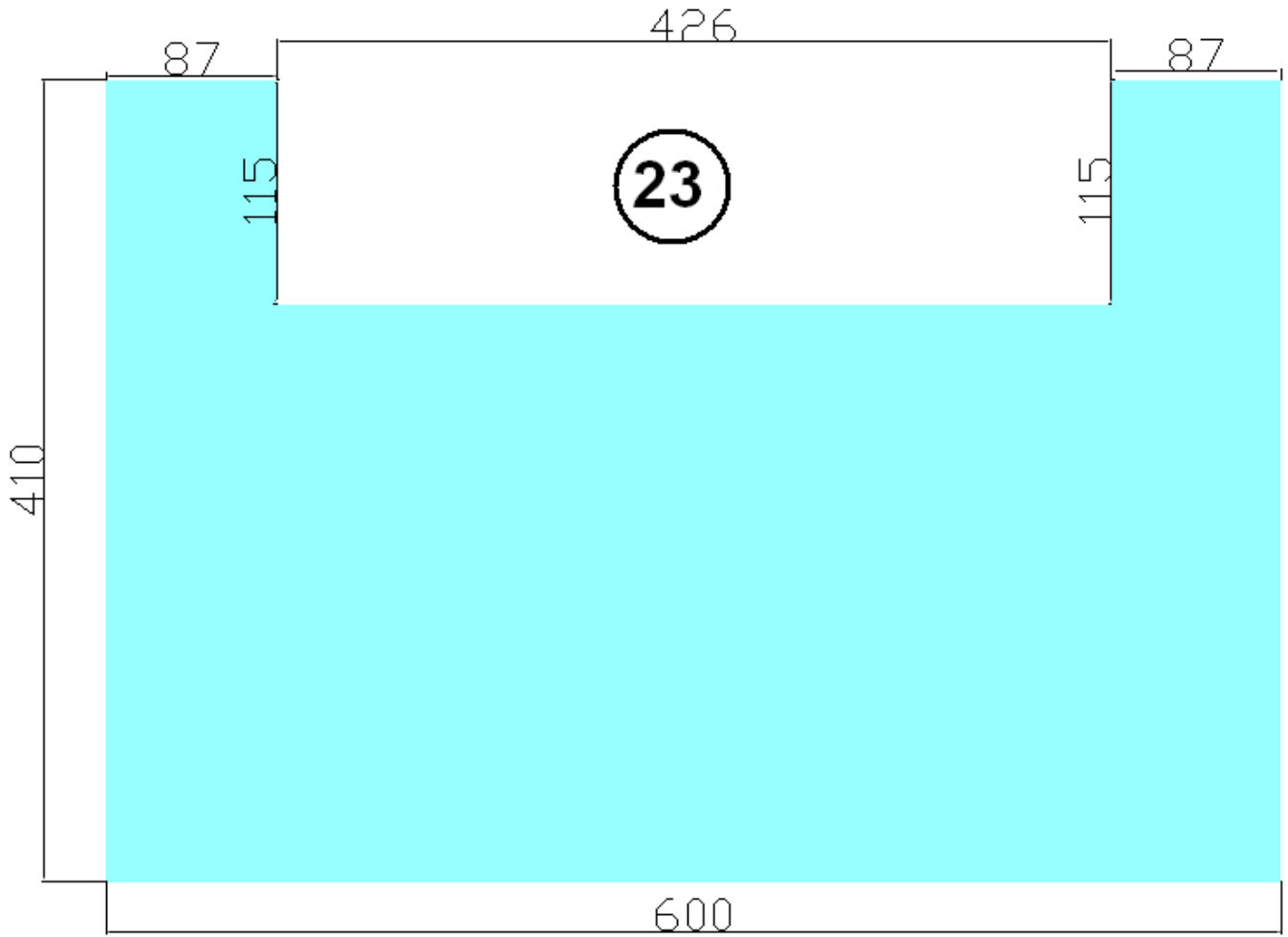

part 24 : **Coversheet for top** (galvanized sheet 0.8 mm)

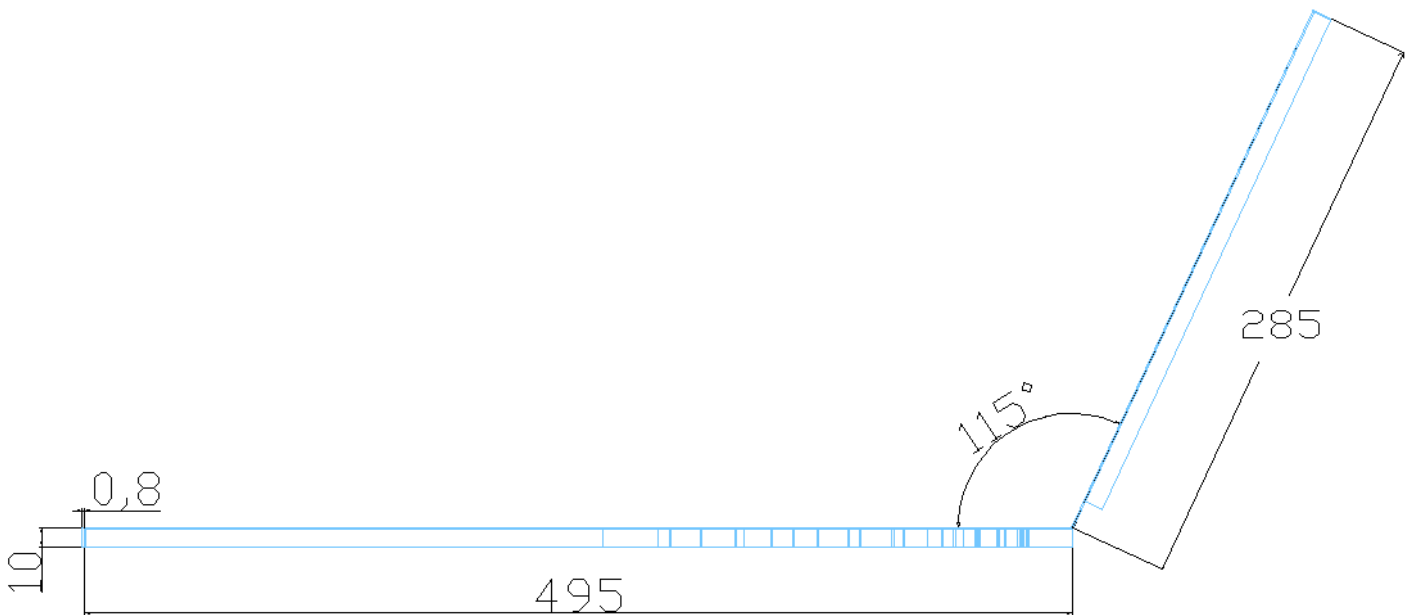
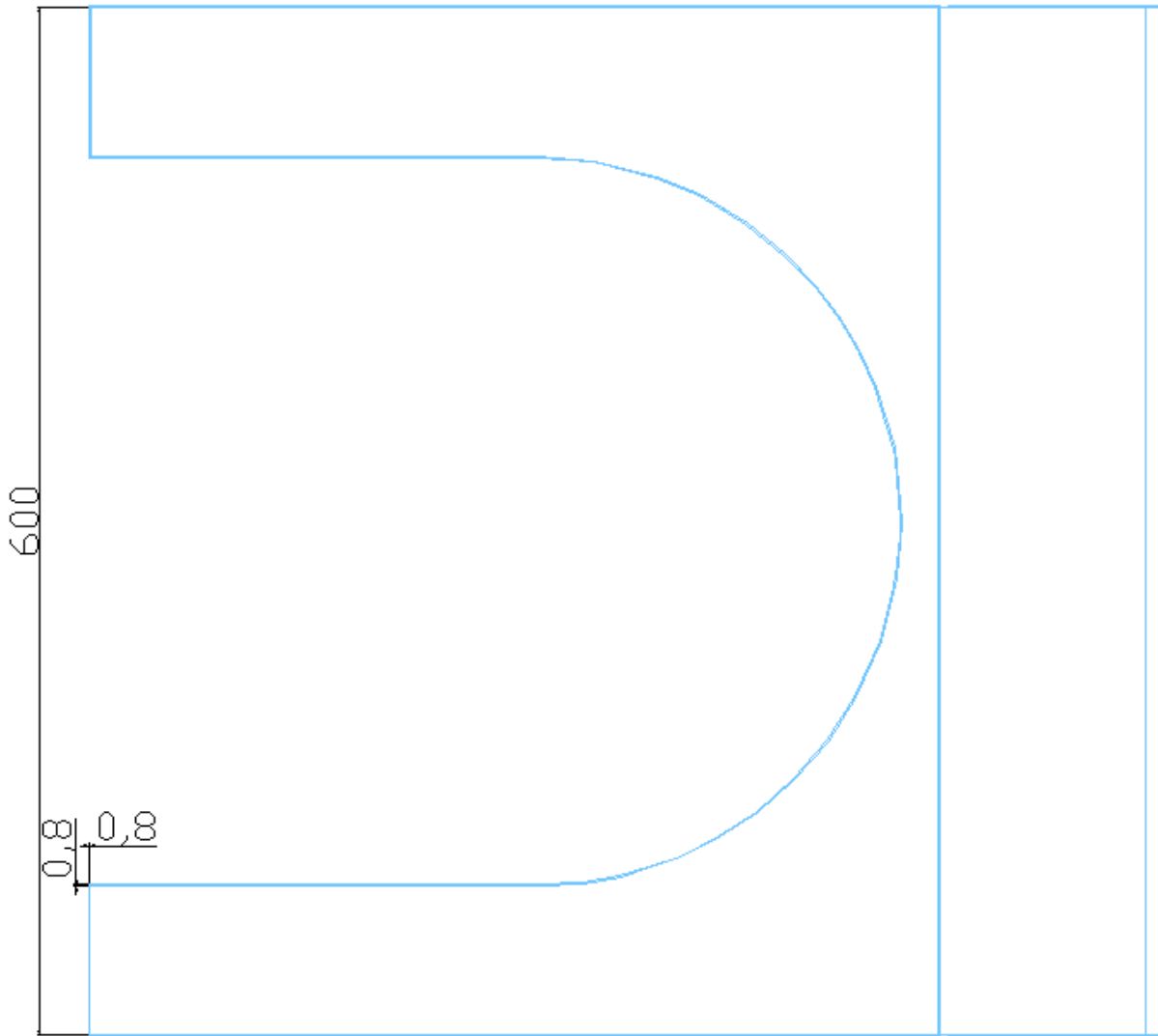

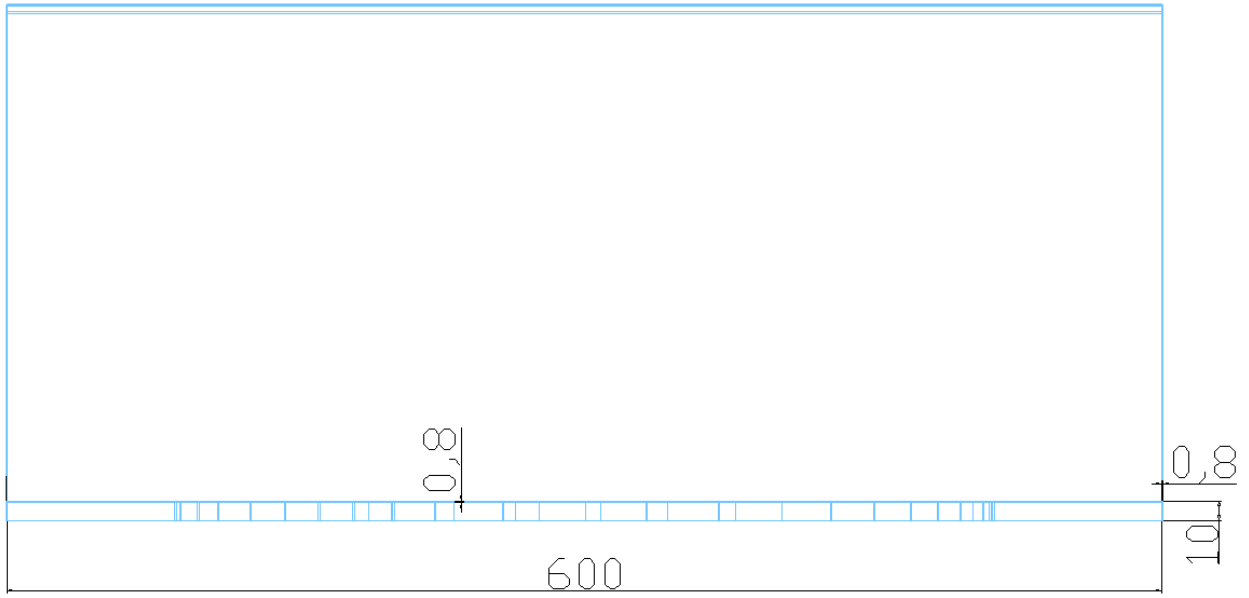

24

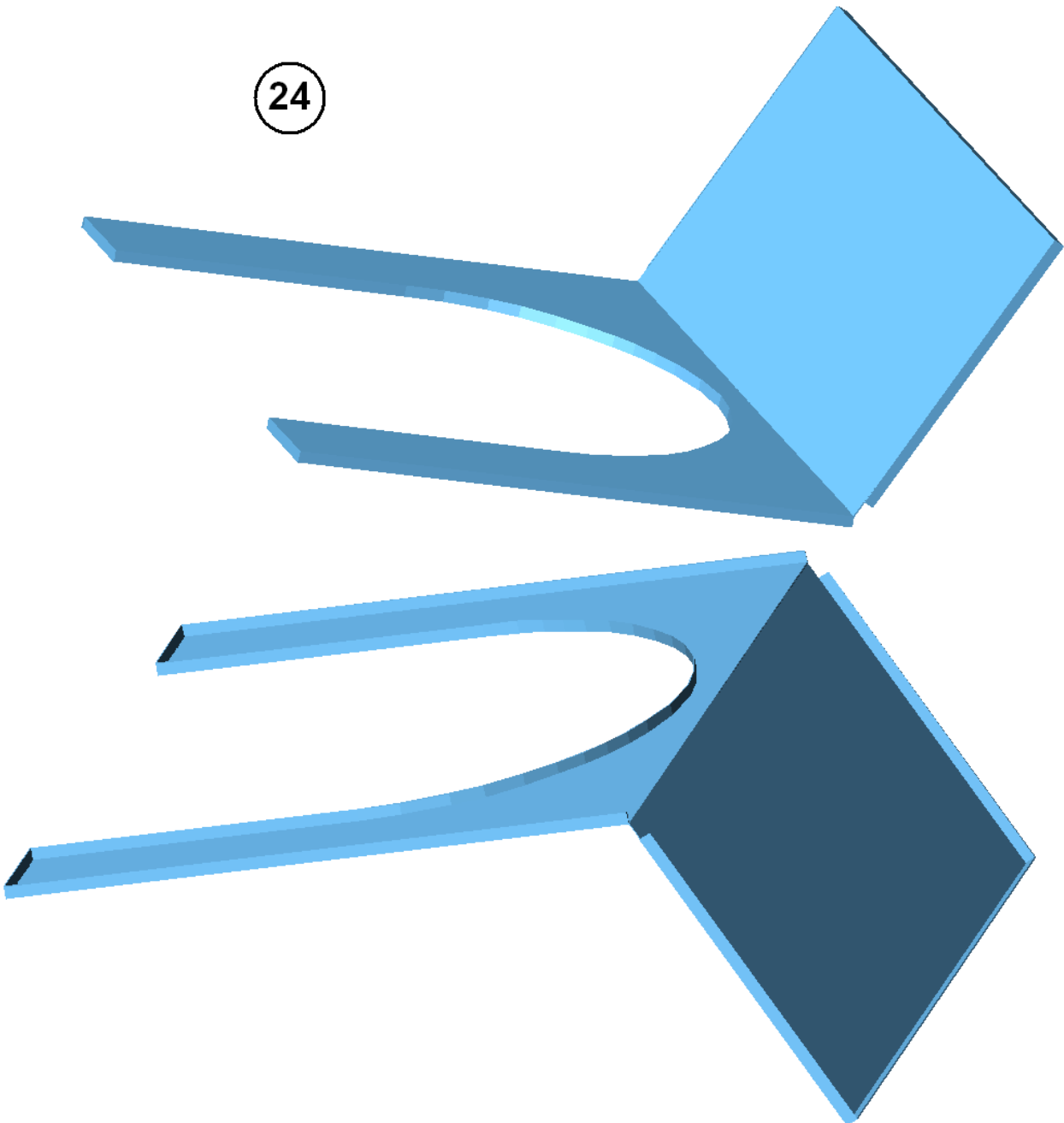

part 25 : sheet for door (iron sheet 1.8 mm)

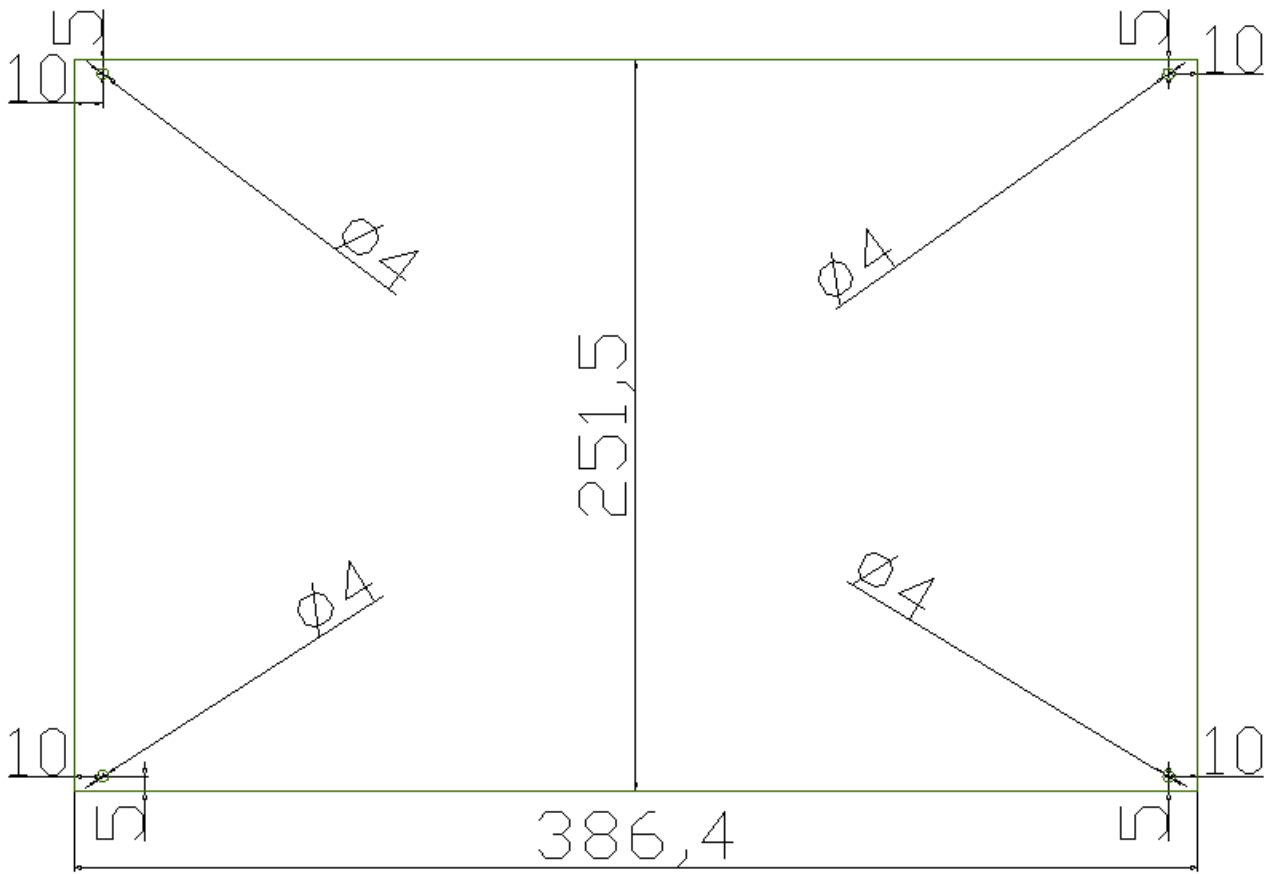

25

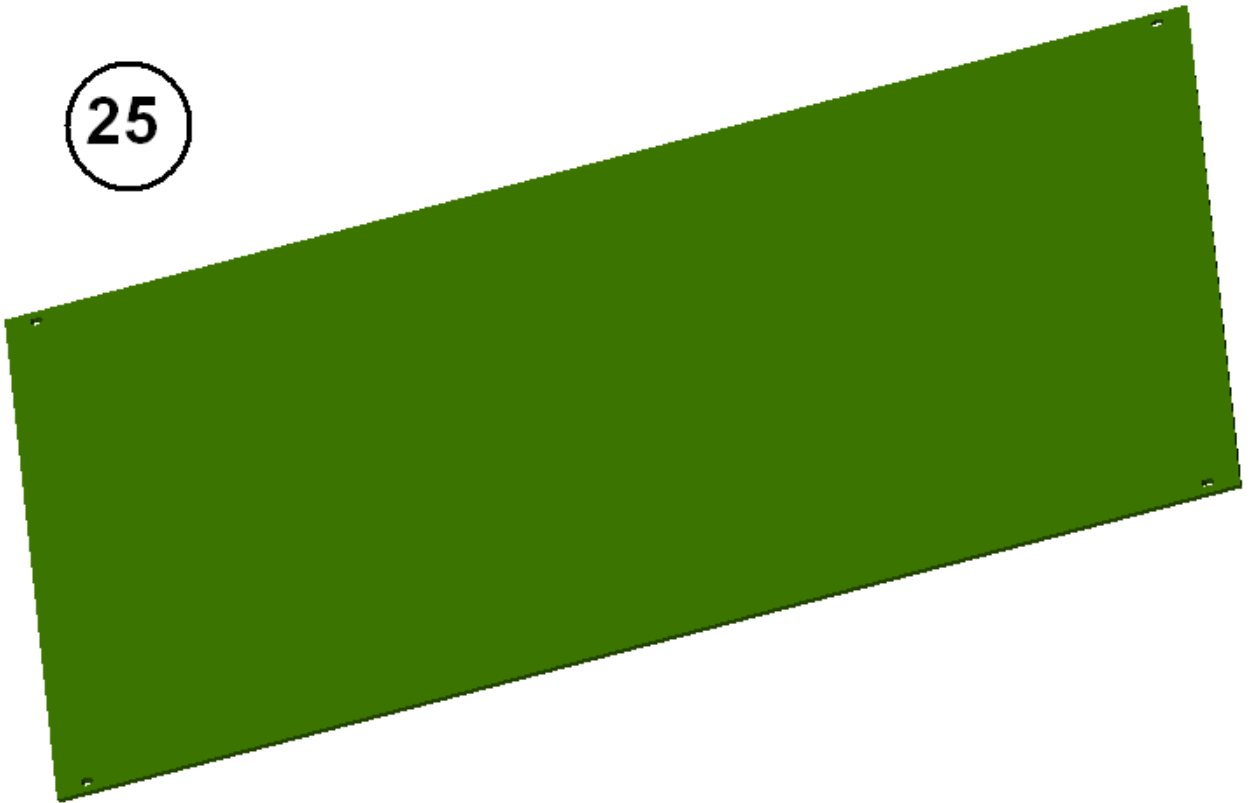

part 26 : spring

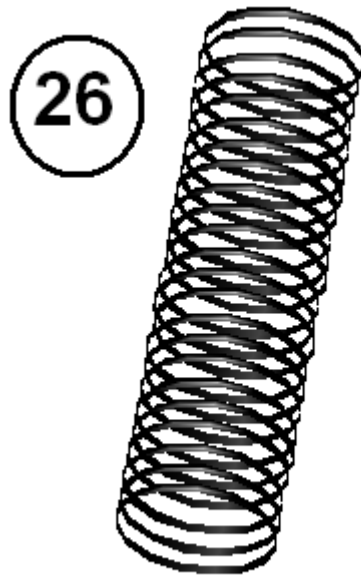

part 27 : nut (M8)

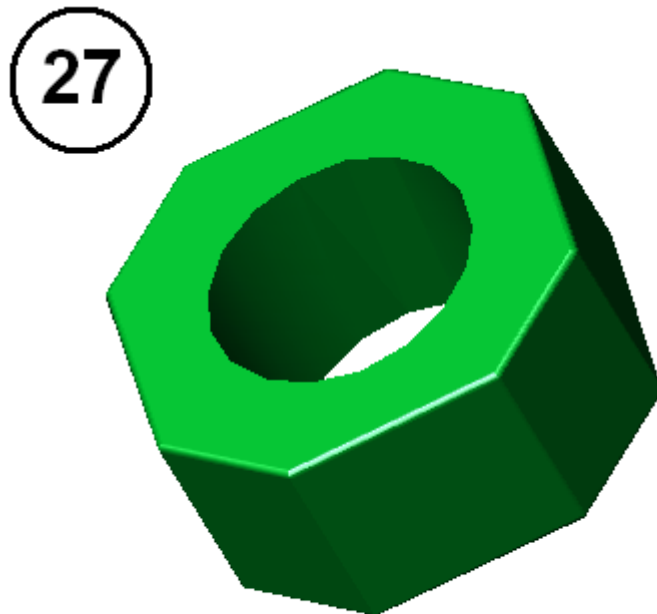

part 28 : Stiffener for secondary reflector (flat bar 25X3)



28

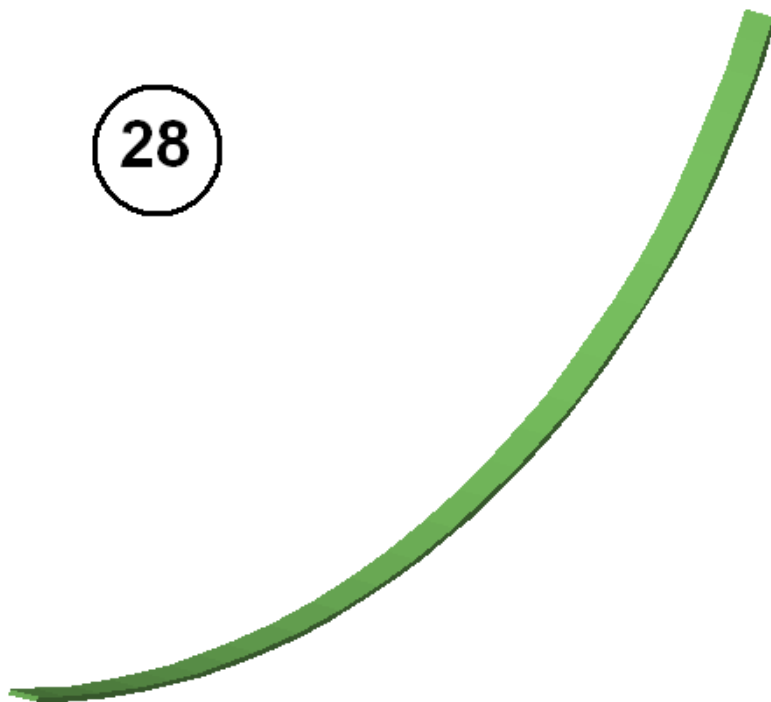

Part 29 : Secondary reflector sheets (Aluminium sheet 1 mm)

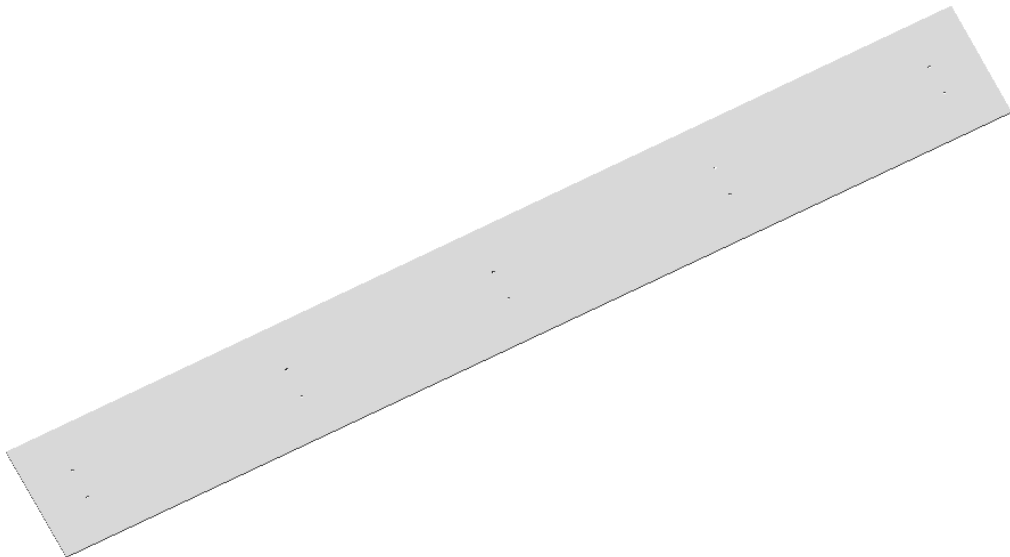
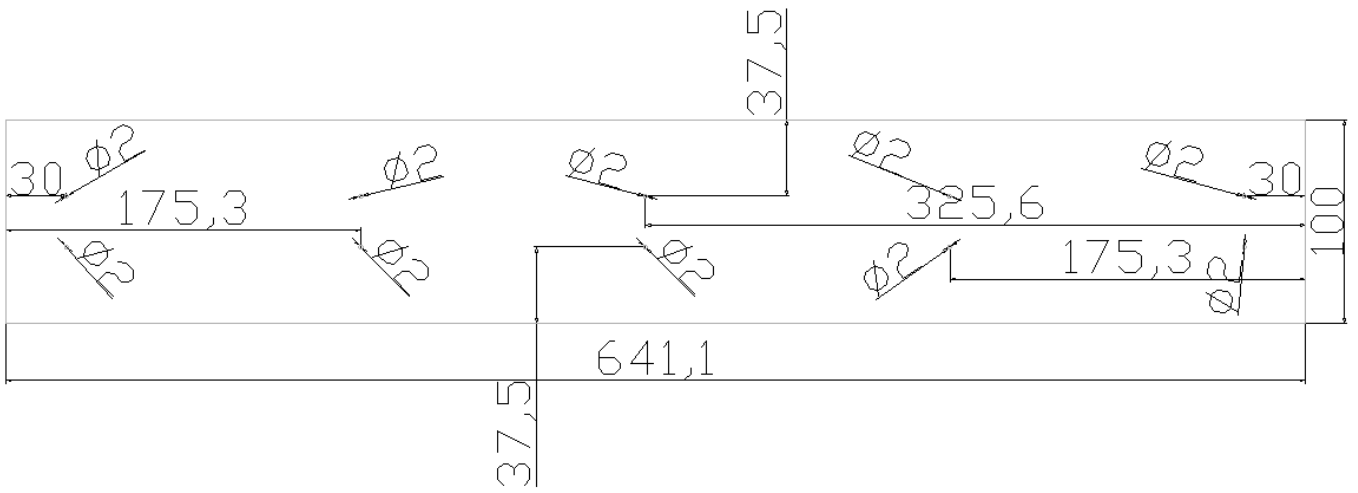

29

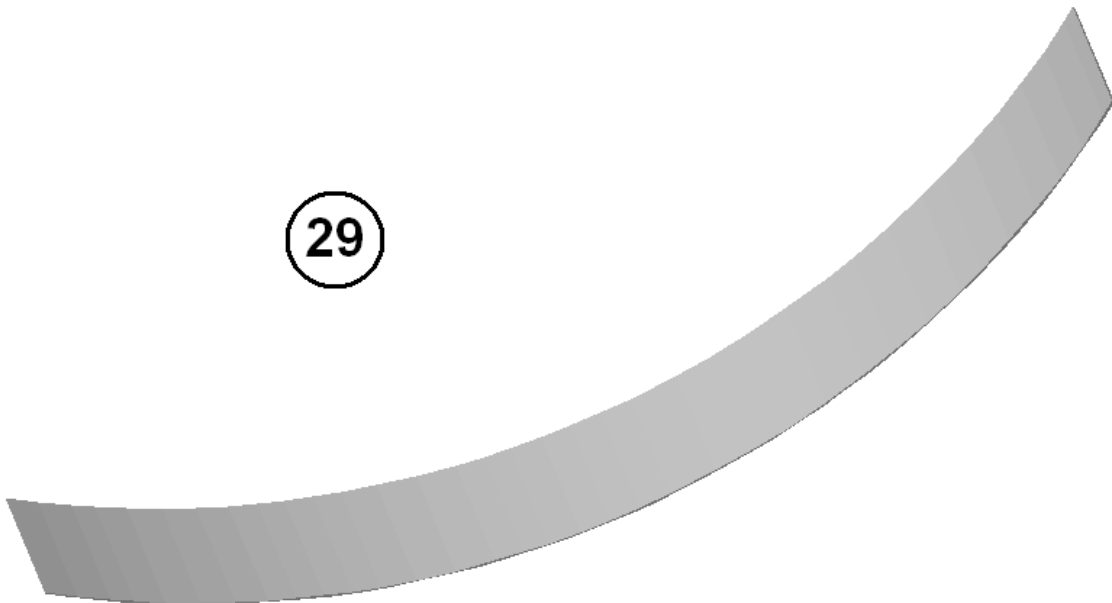

2) Procedure of Assembly

Step 1

Weld step 1 to step 15

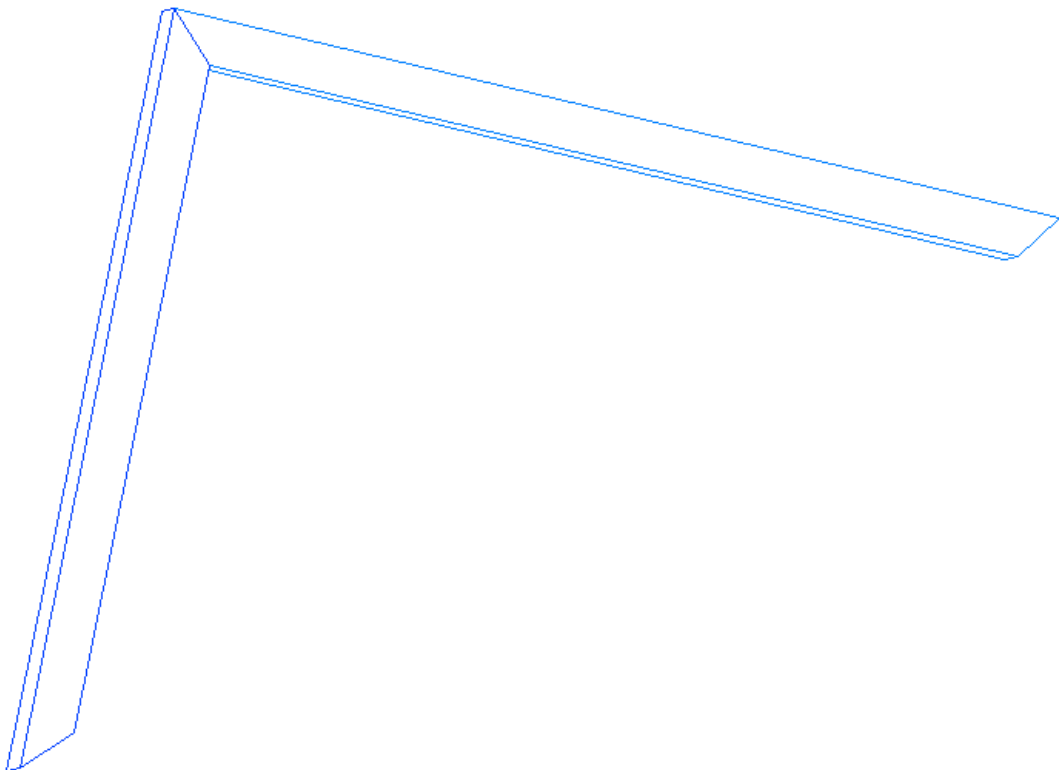
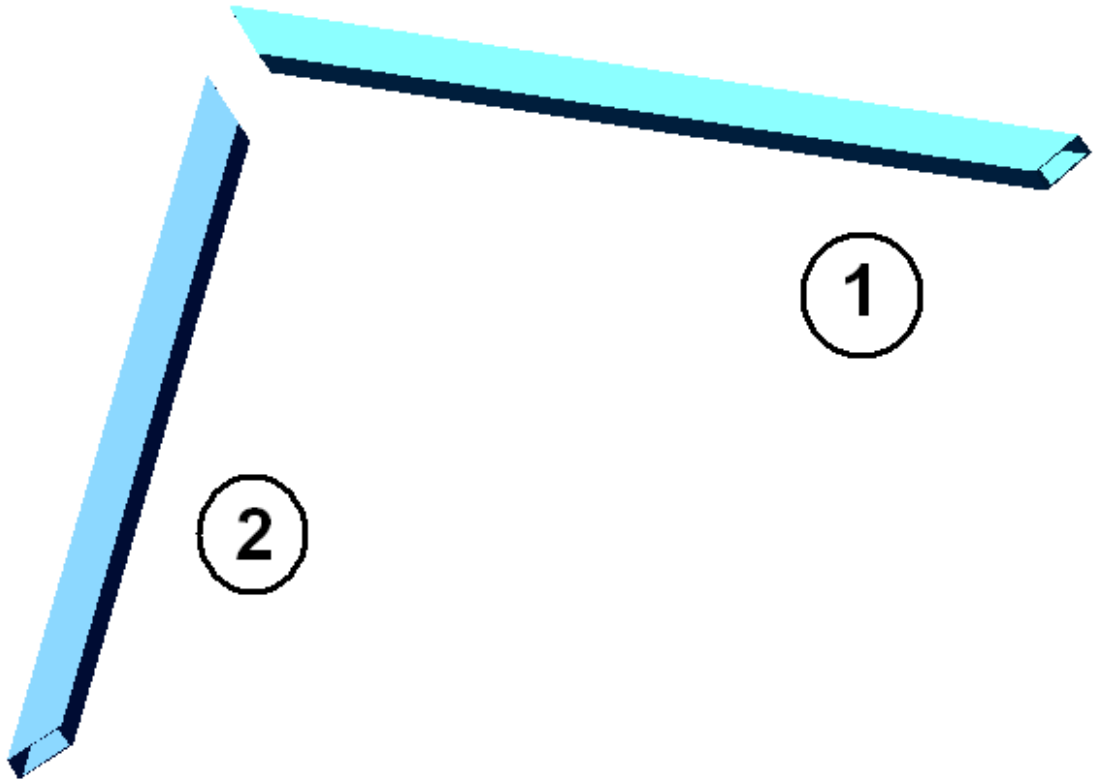

Step 2

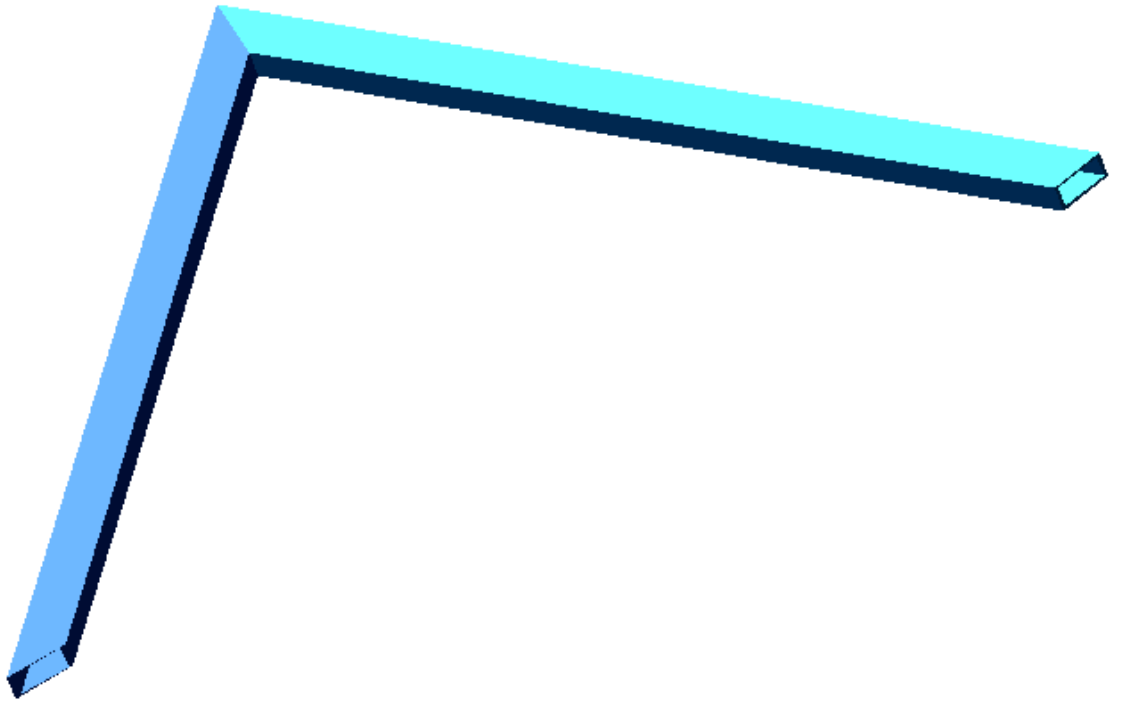

3

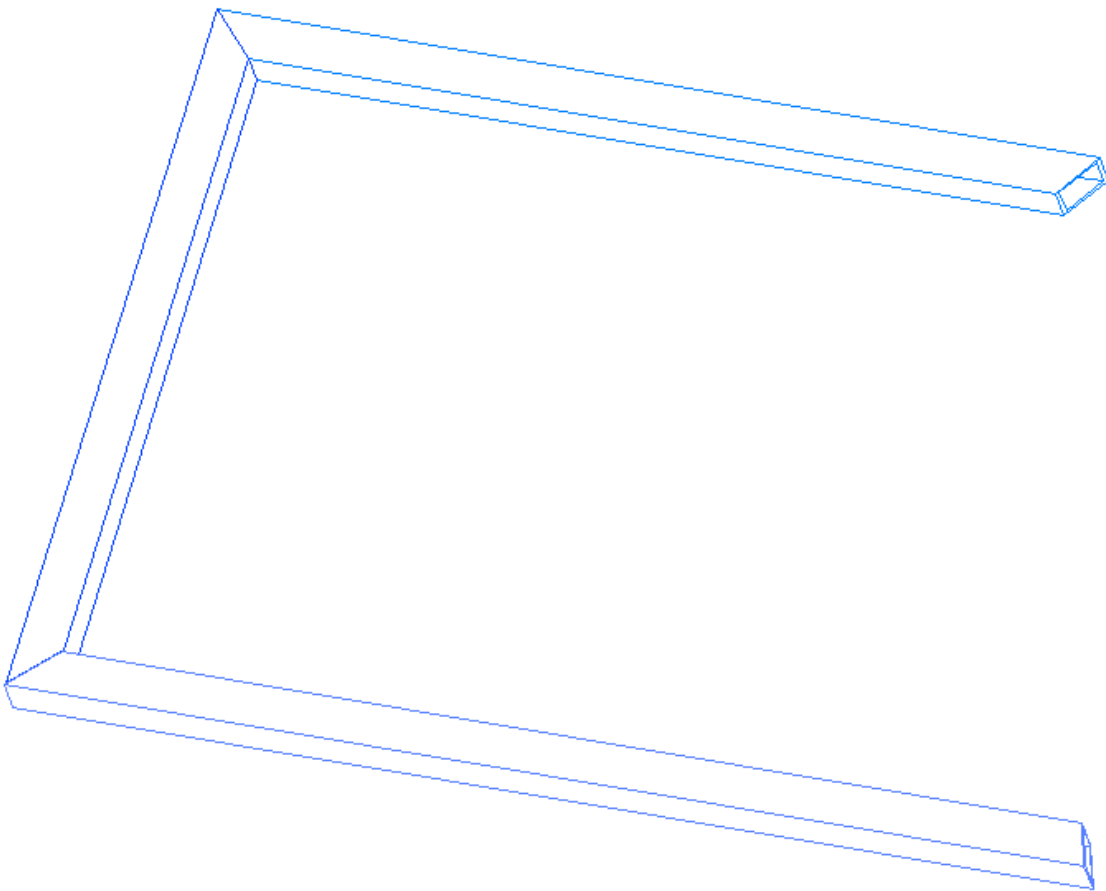

Step 3

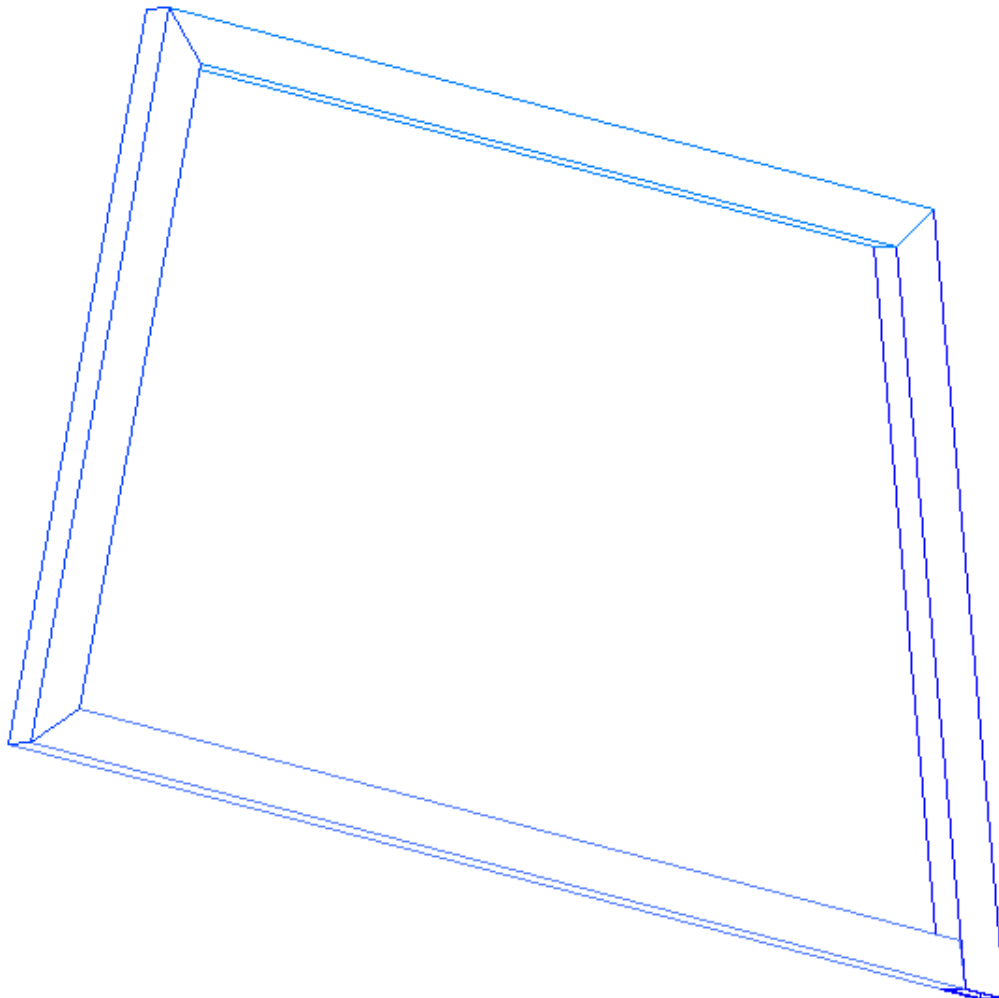
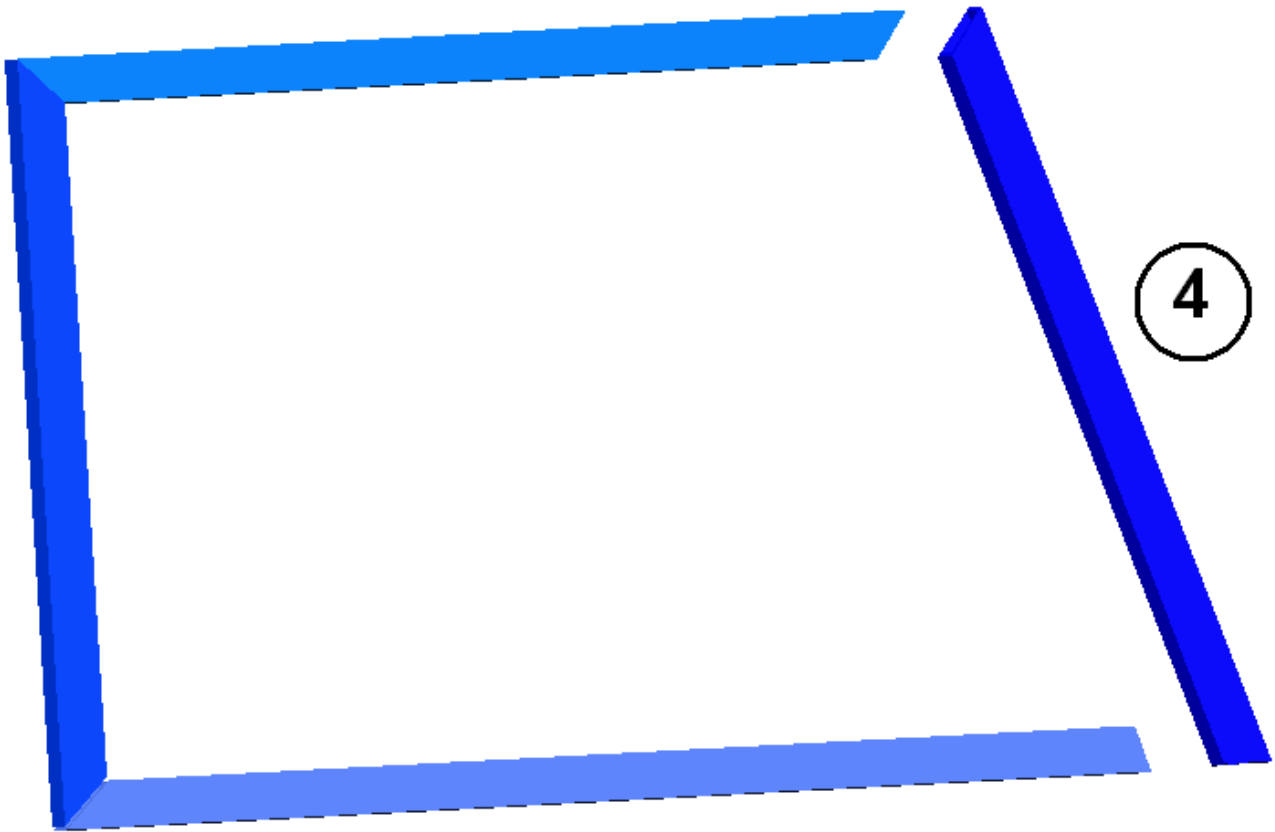

Step 4

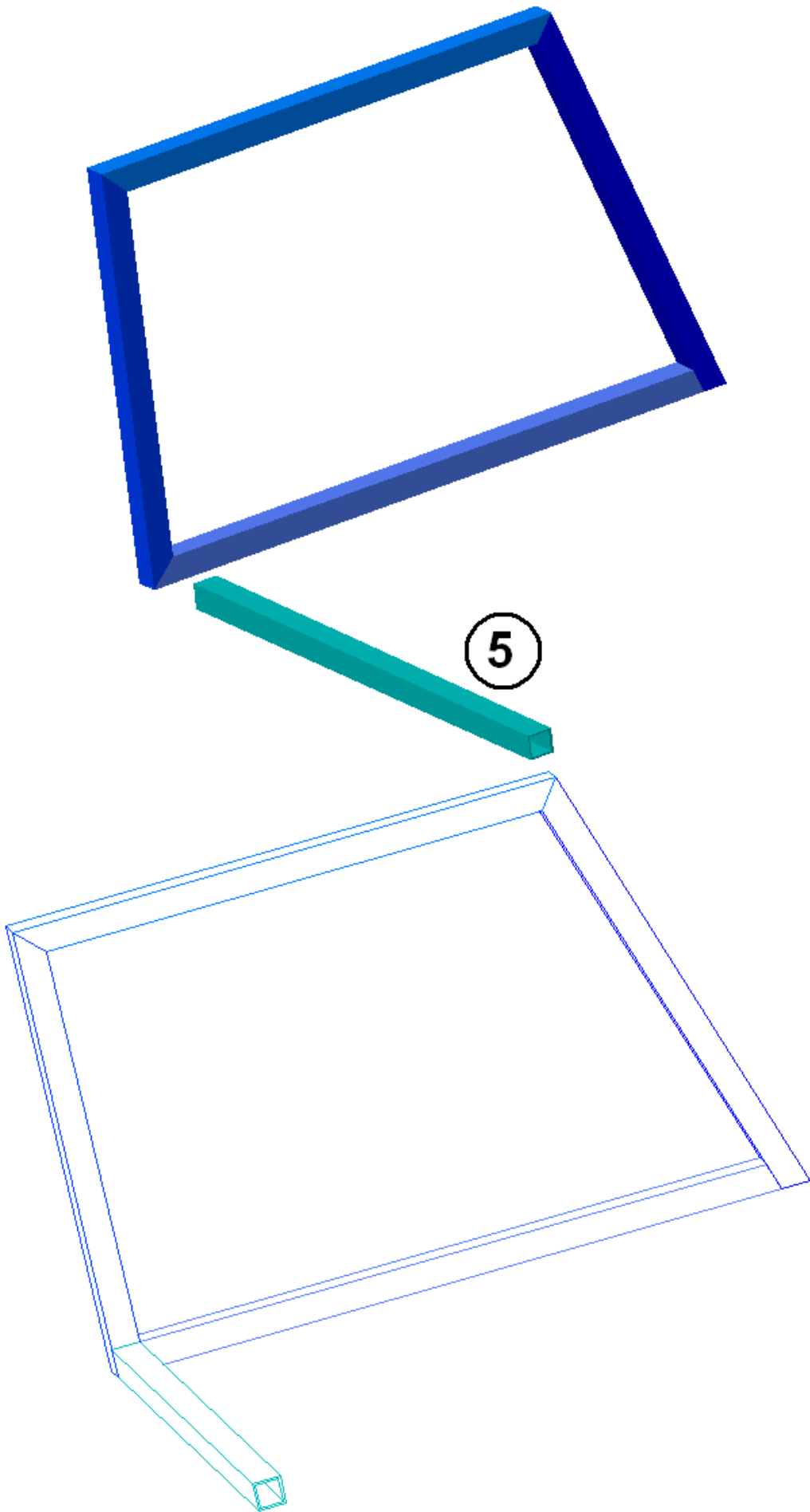

Step 5

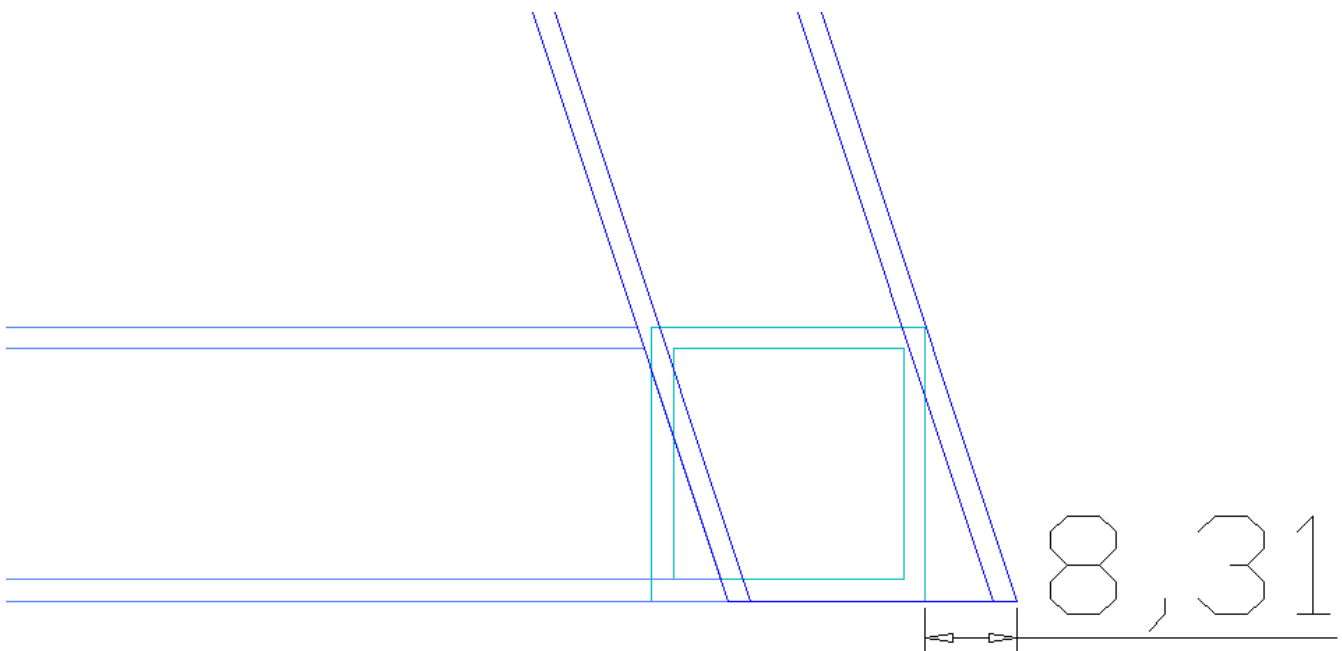
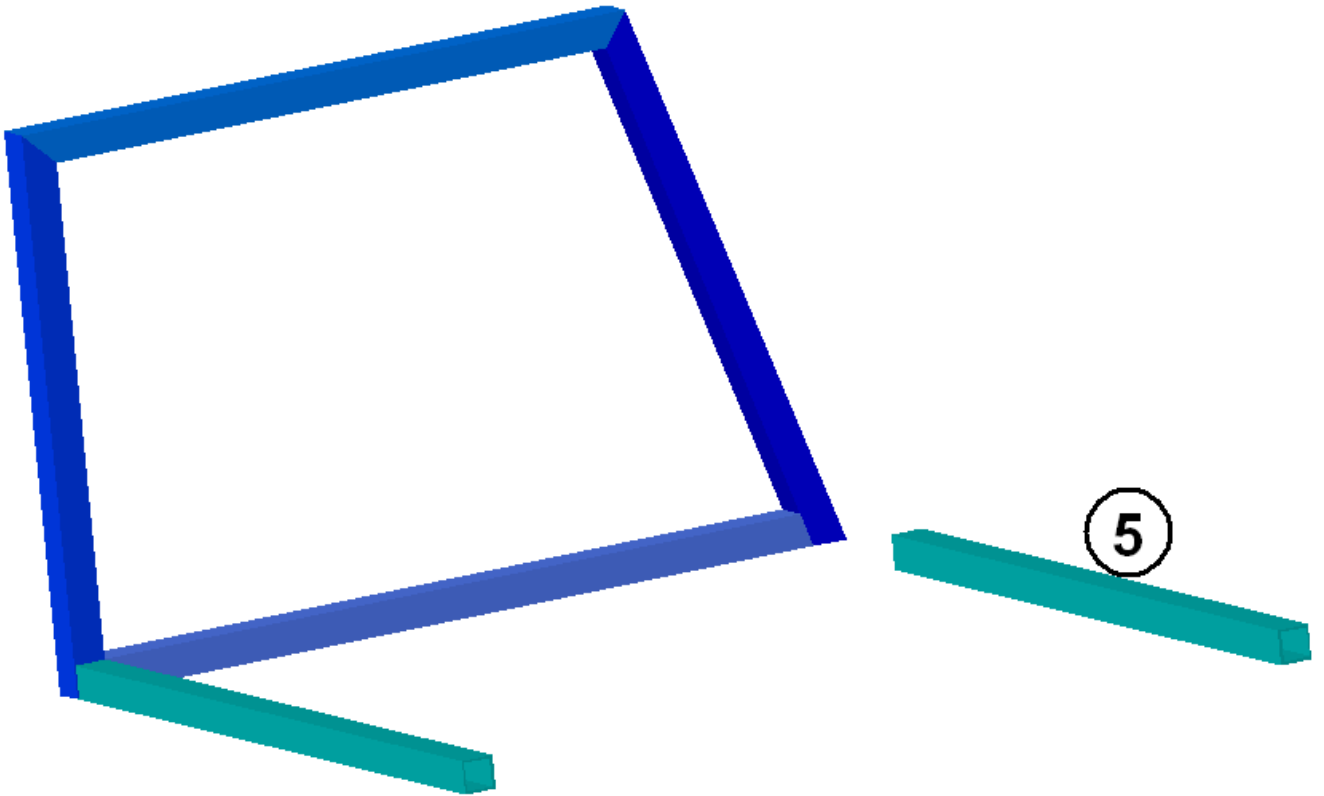

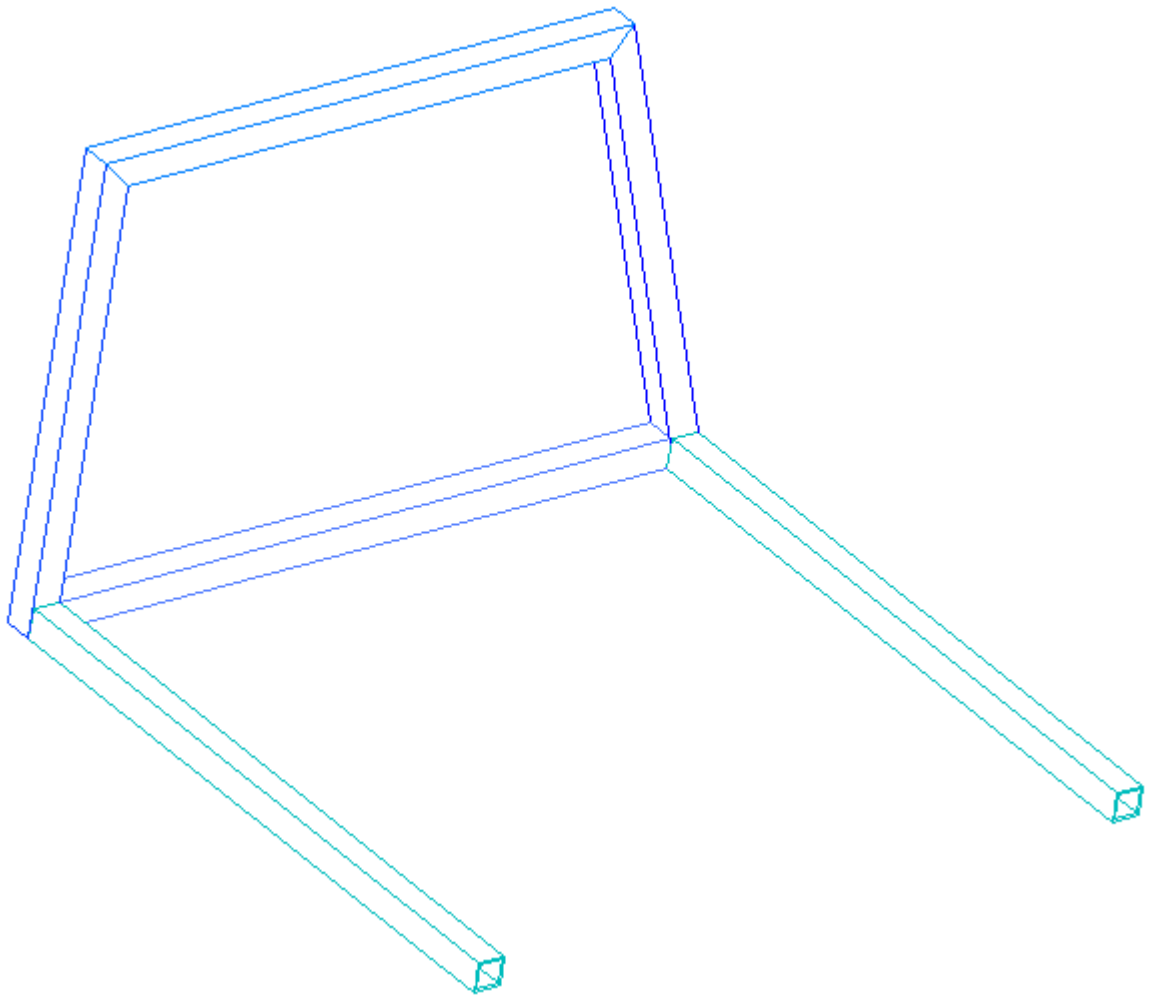

Step 6

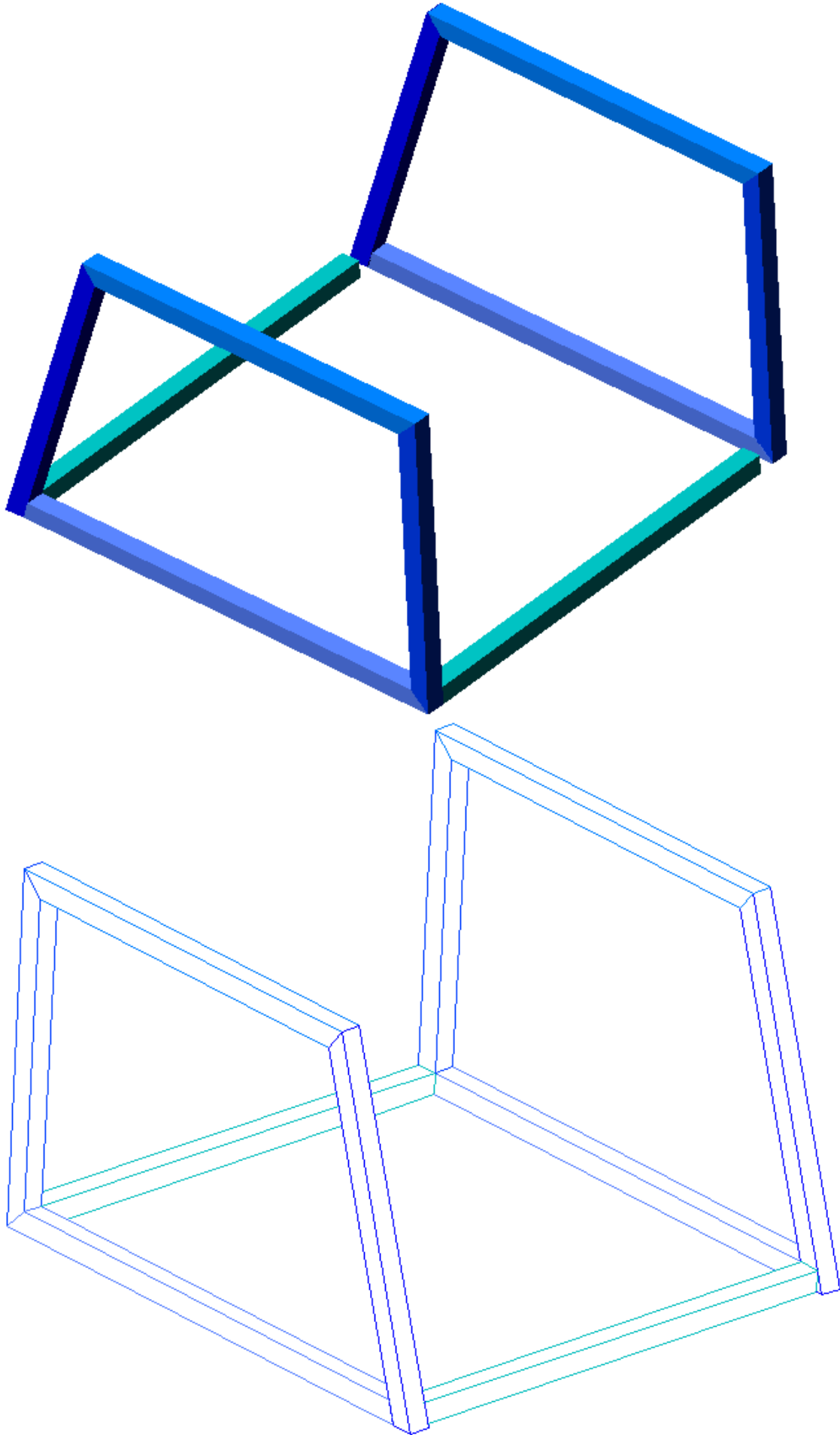

Step 7

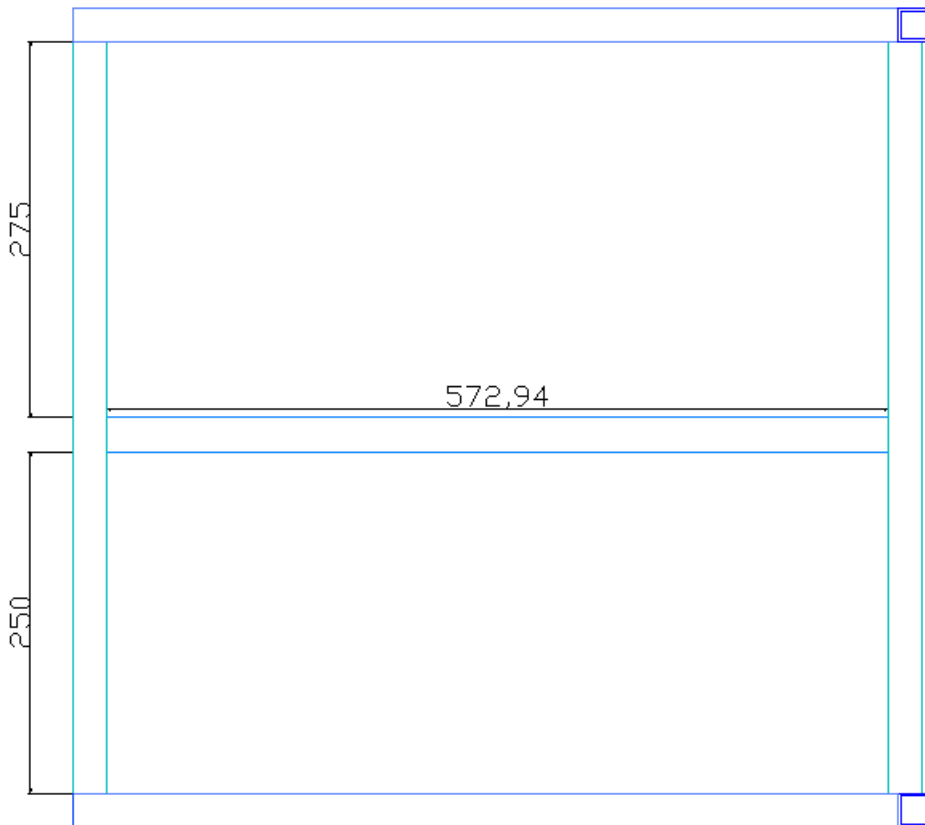
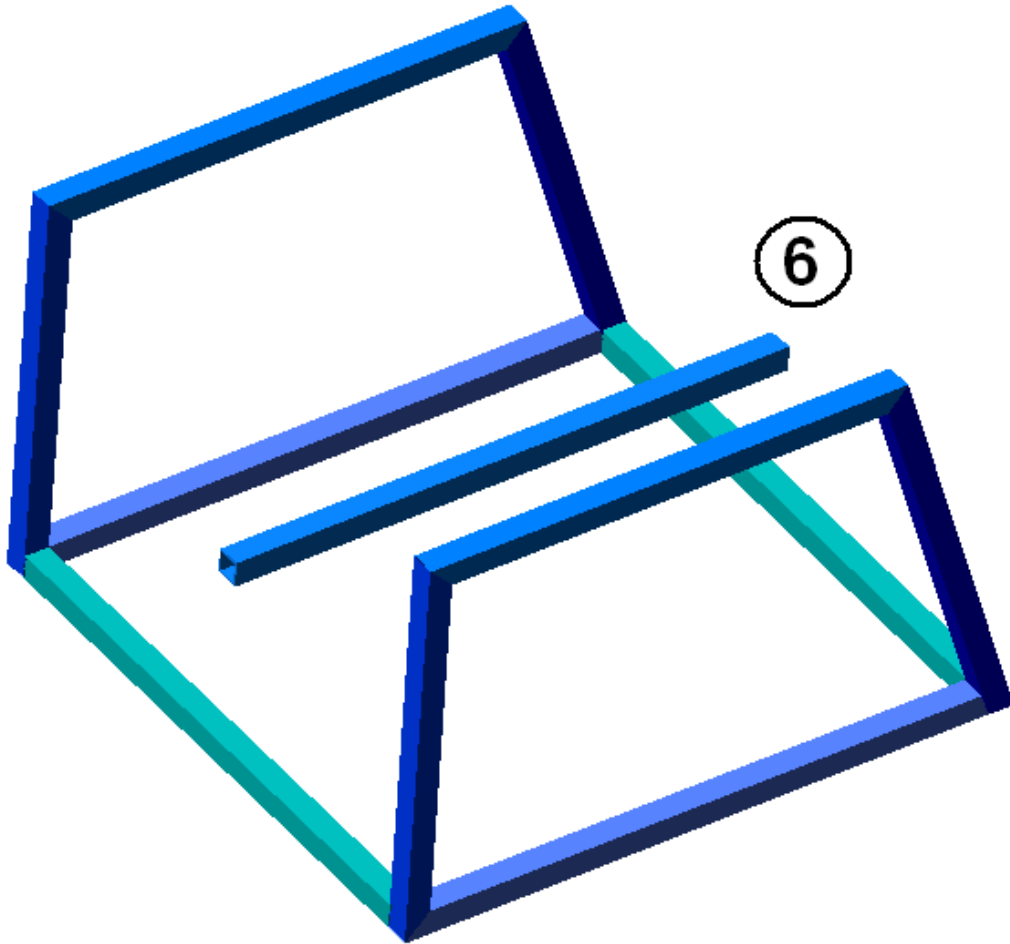

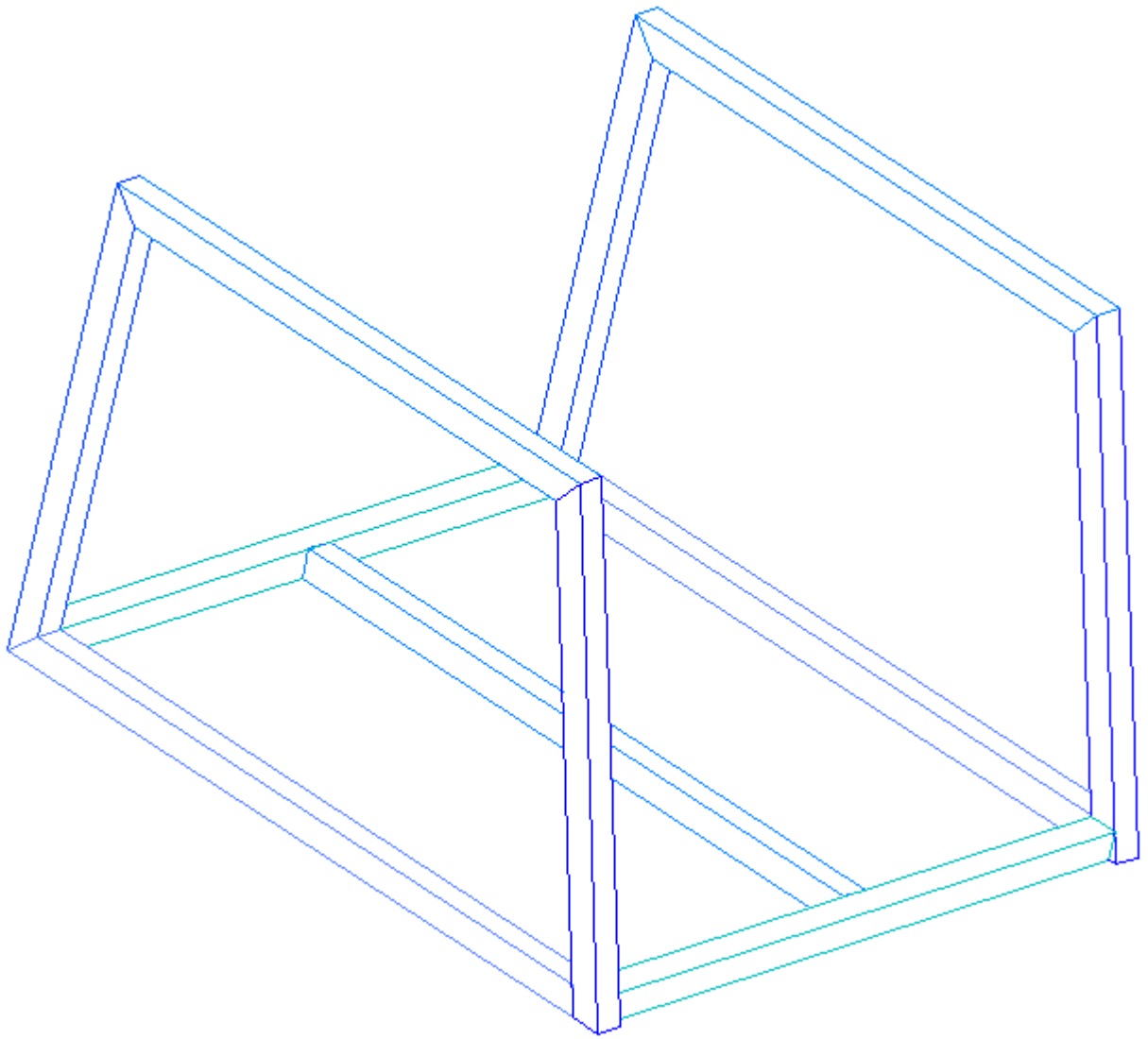

Step 8

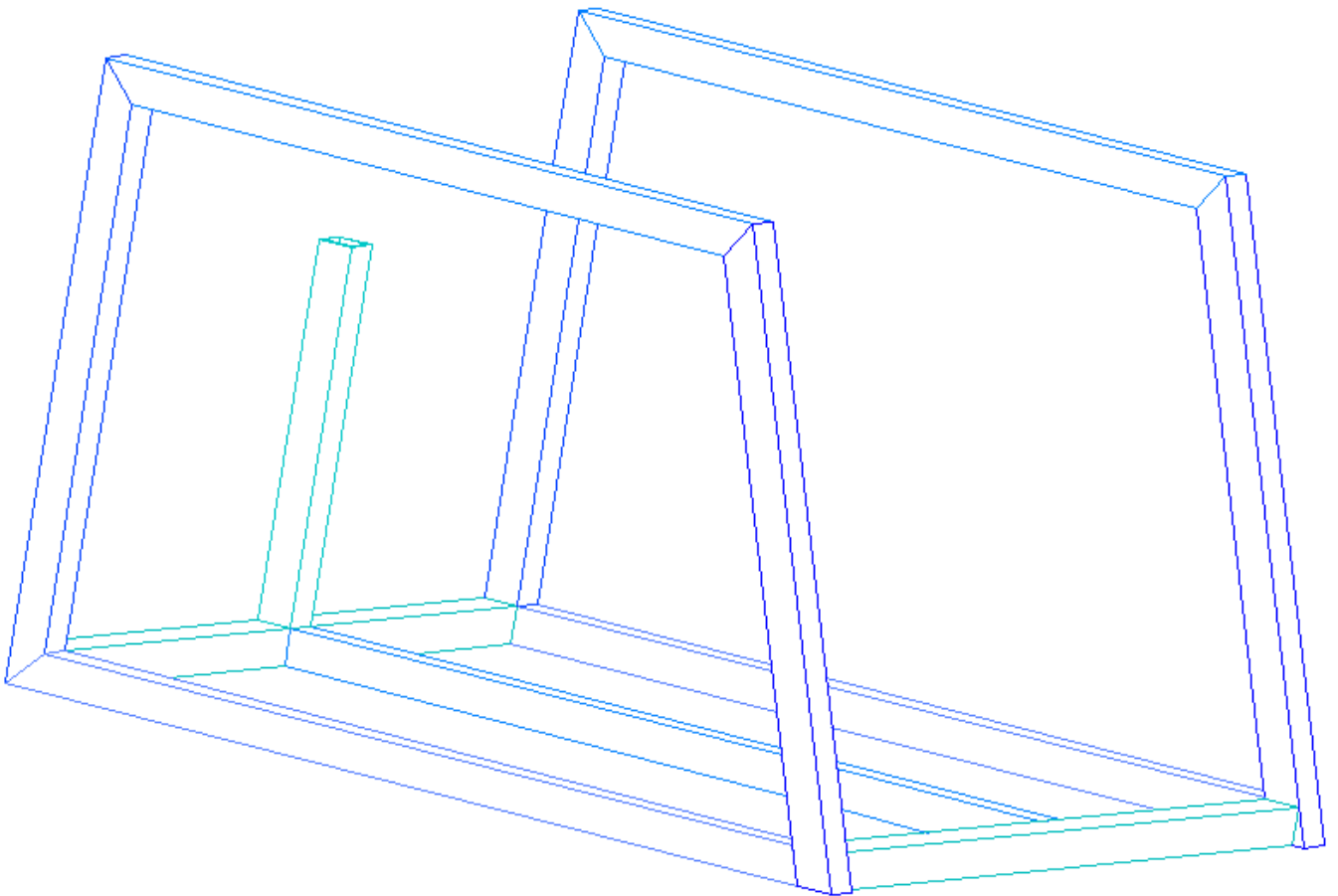
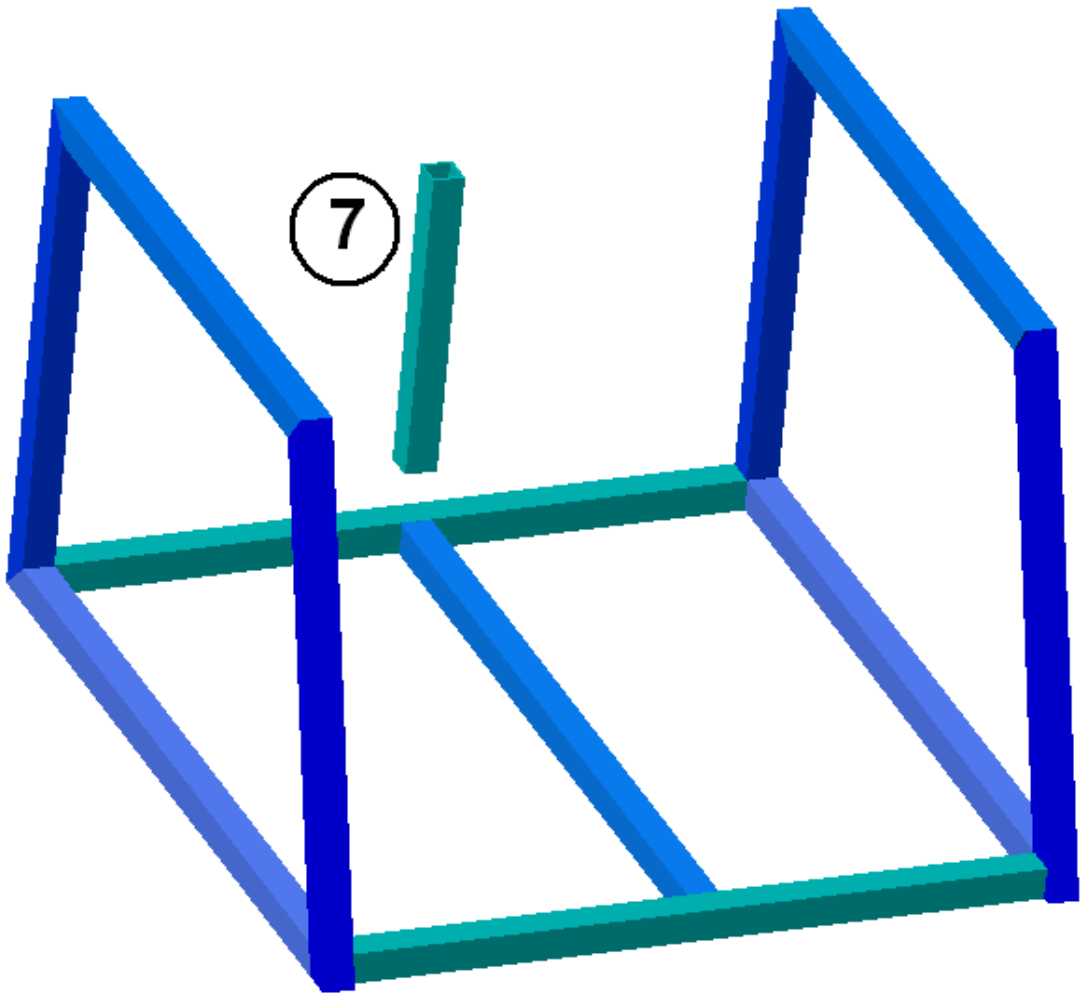

Step 9

5

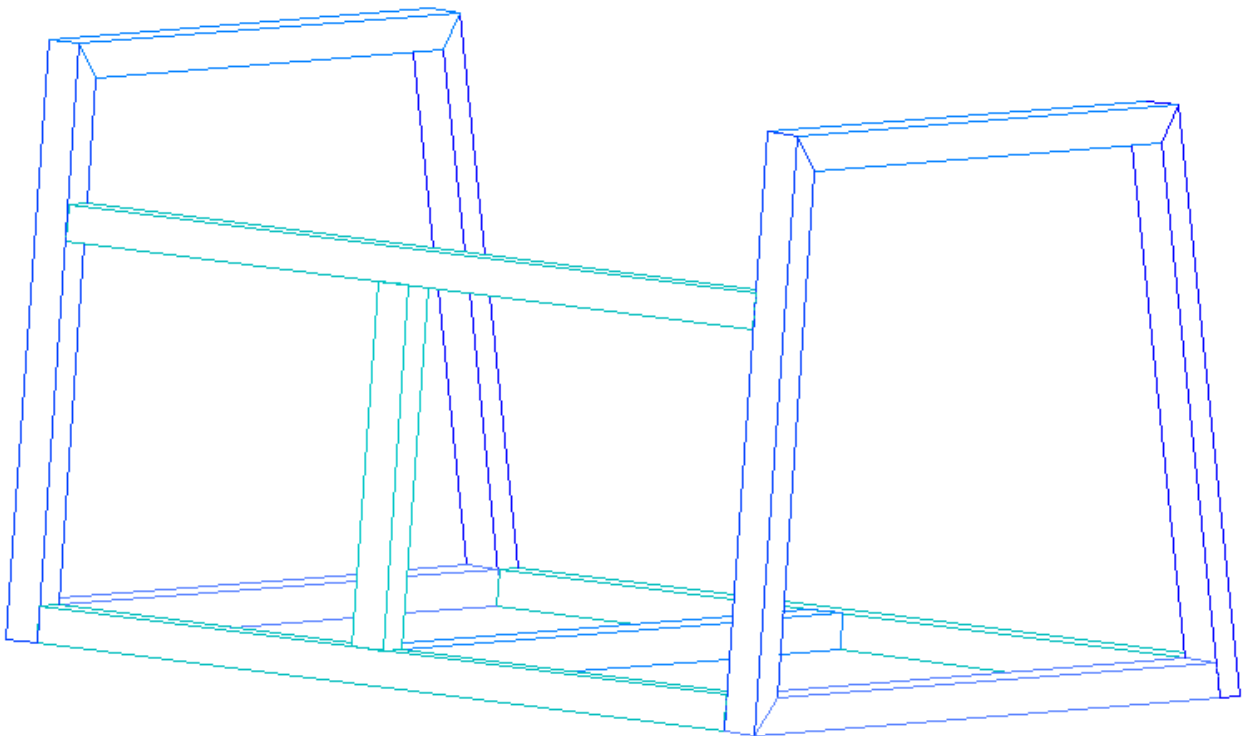
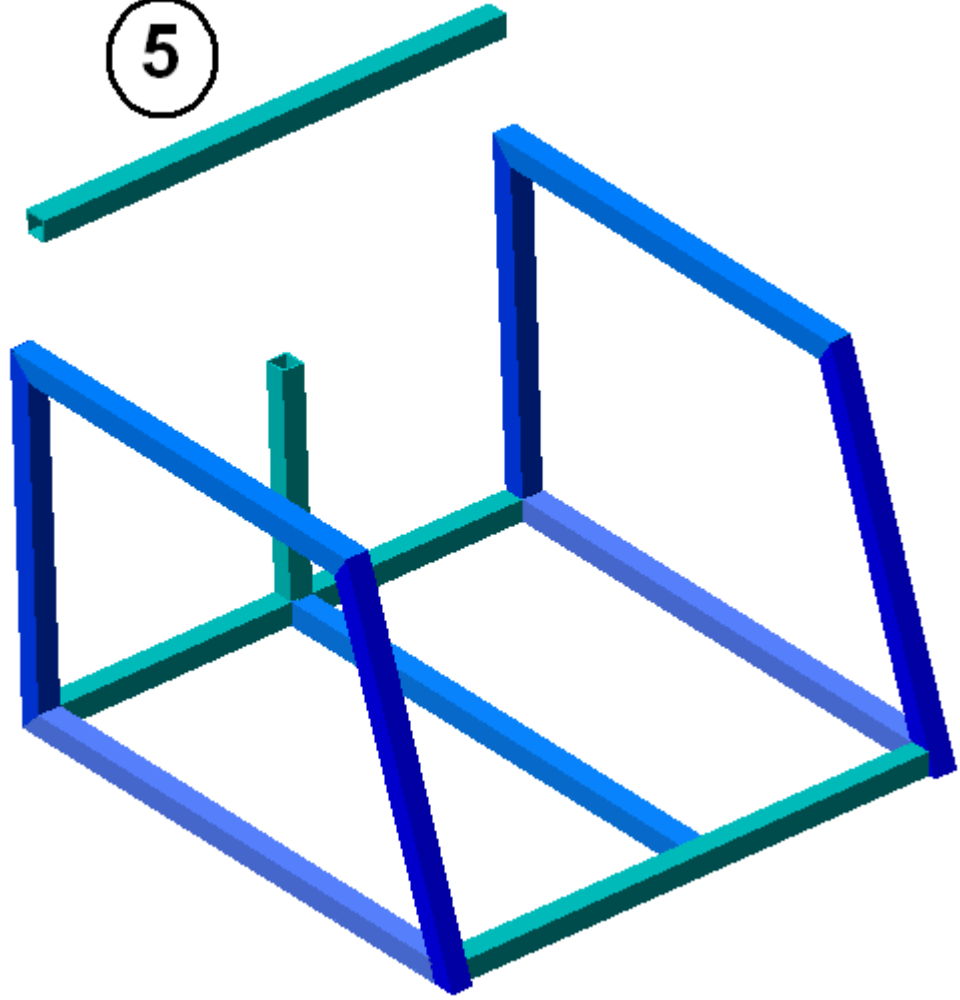

Step 10

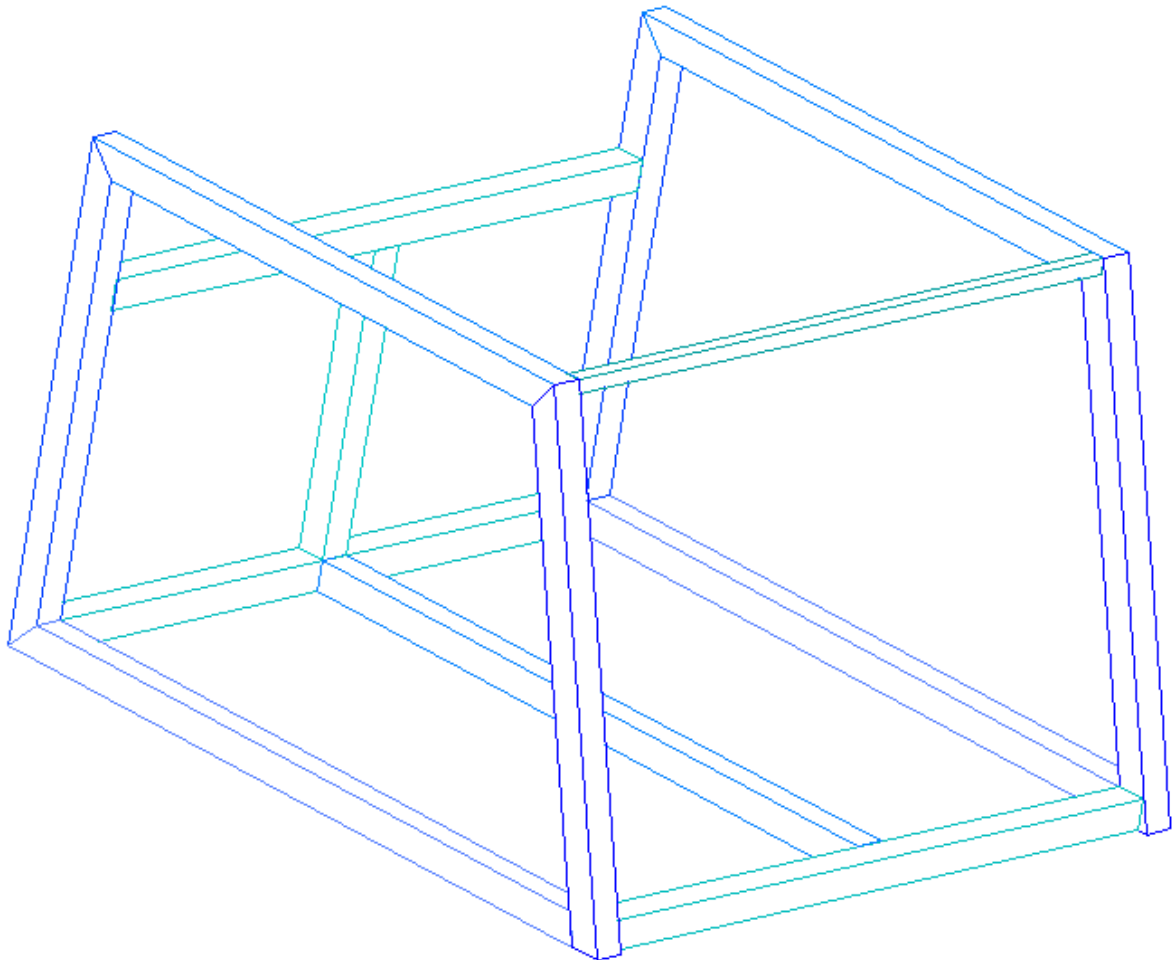
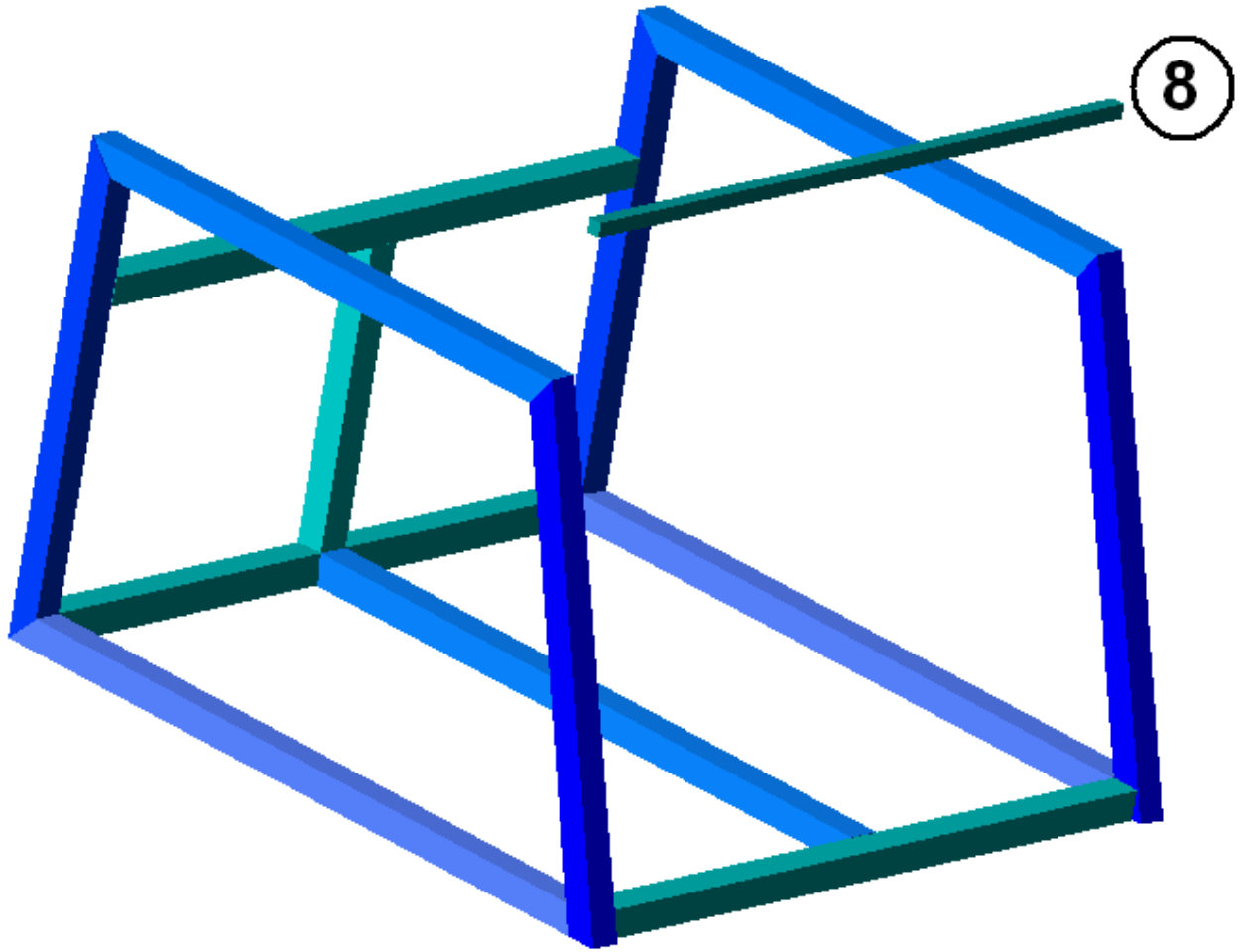

Step 11

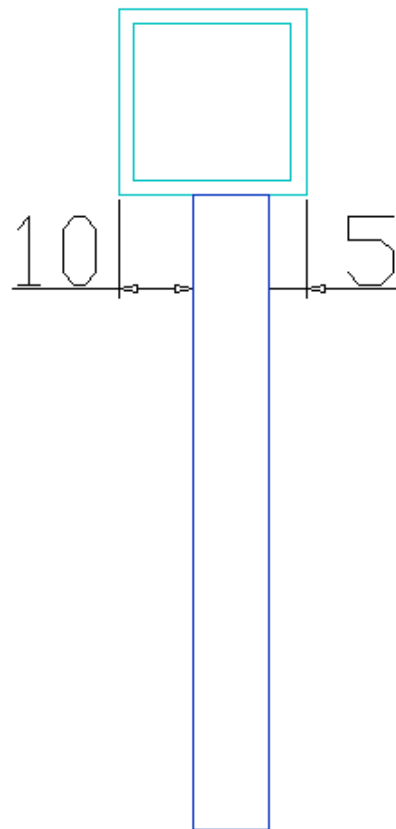
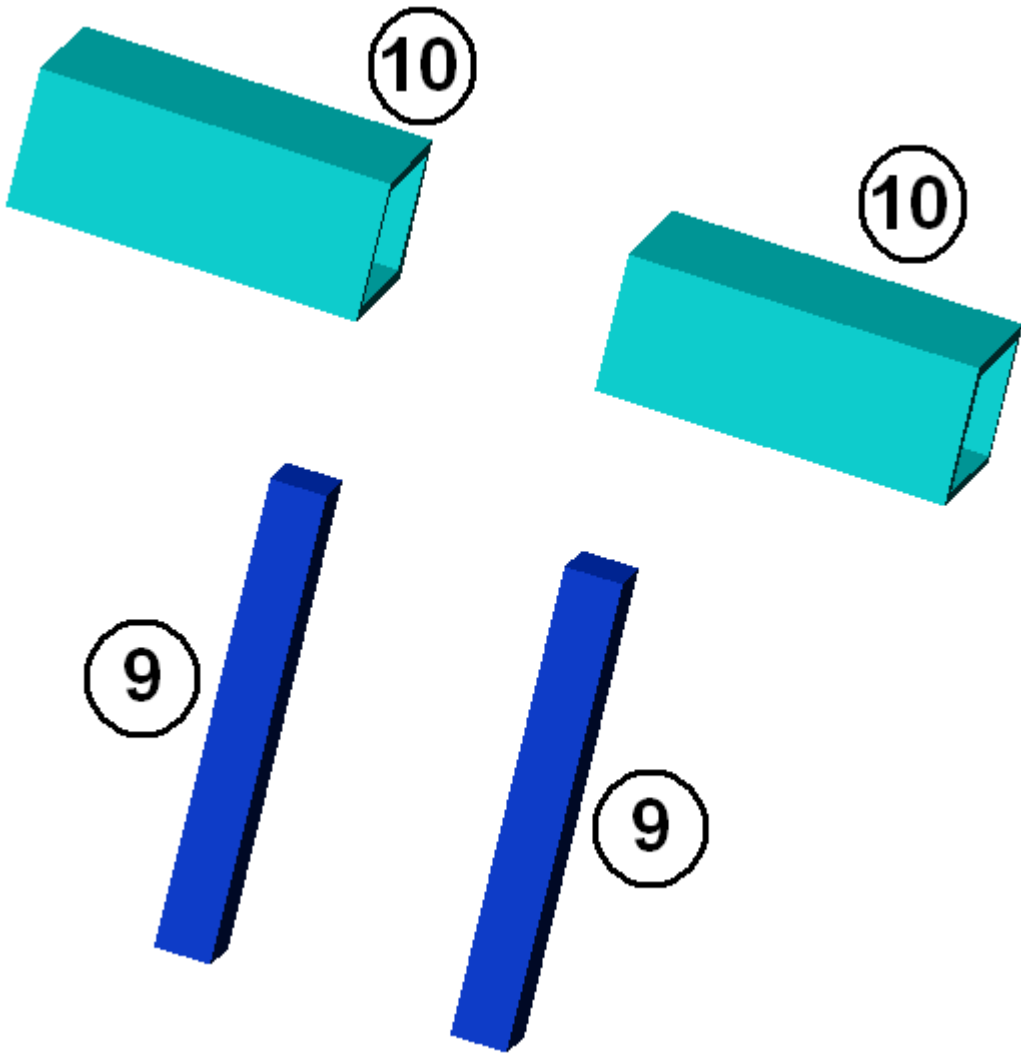

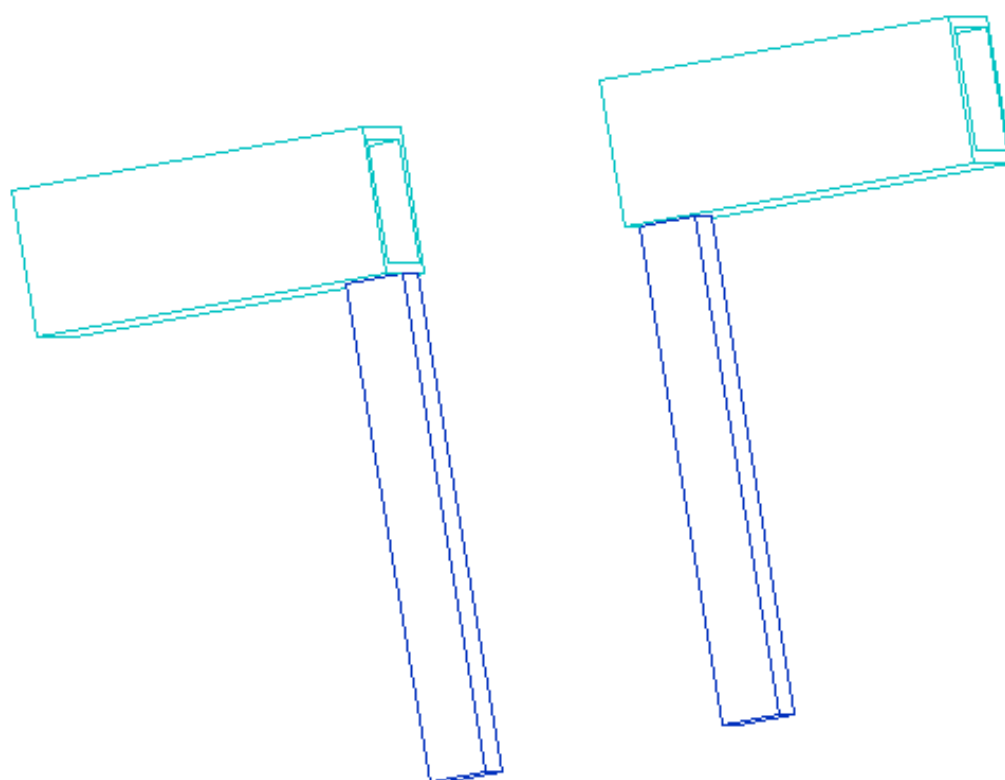
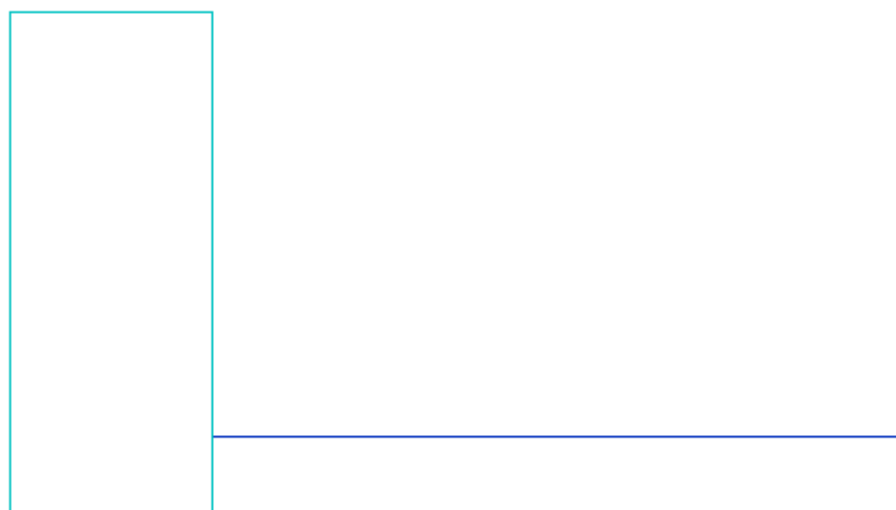

Step 12

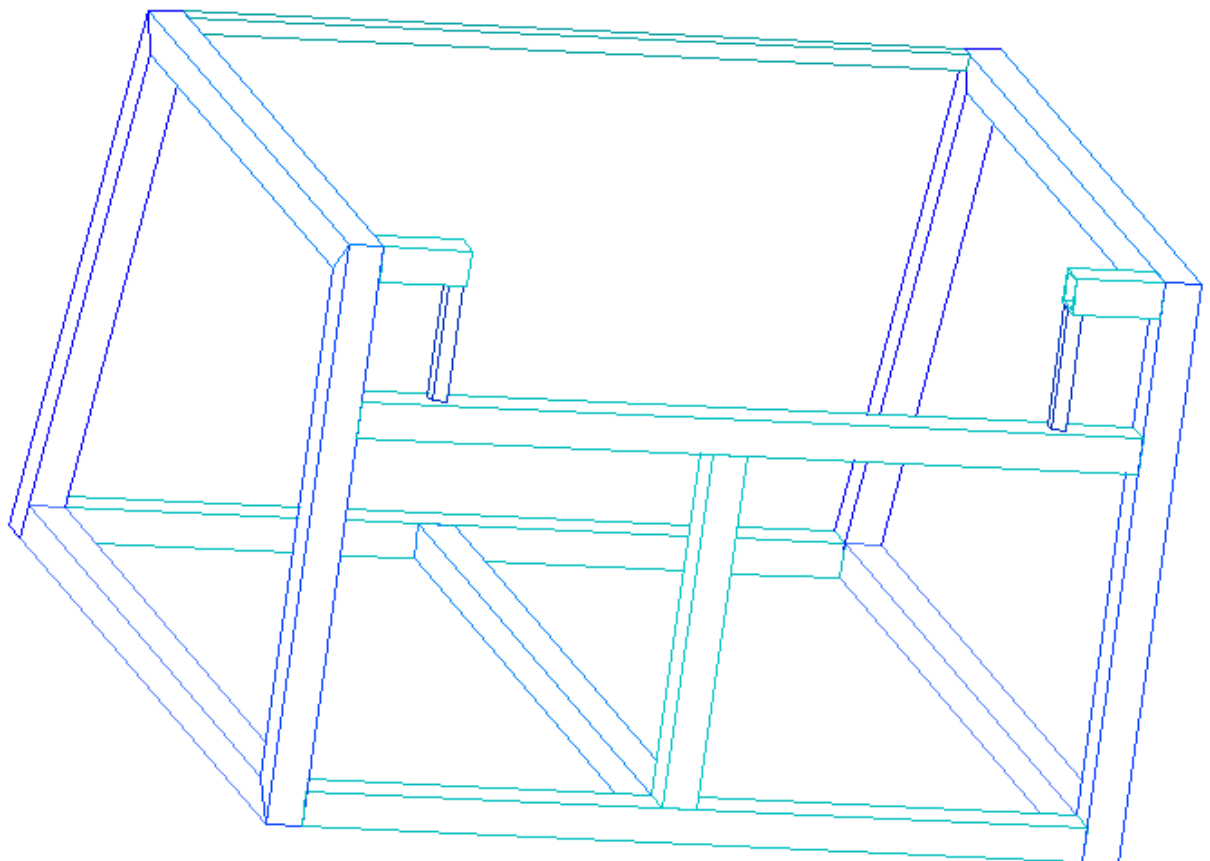
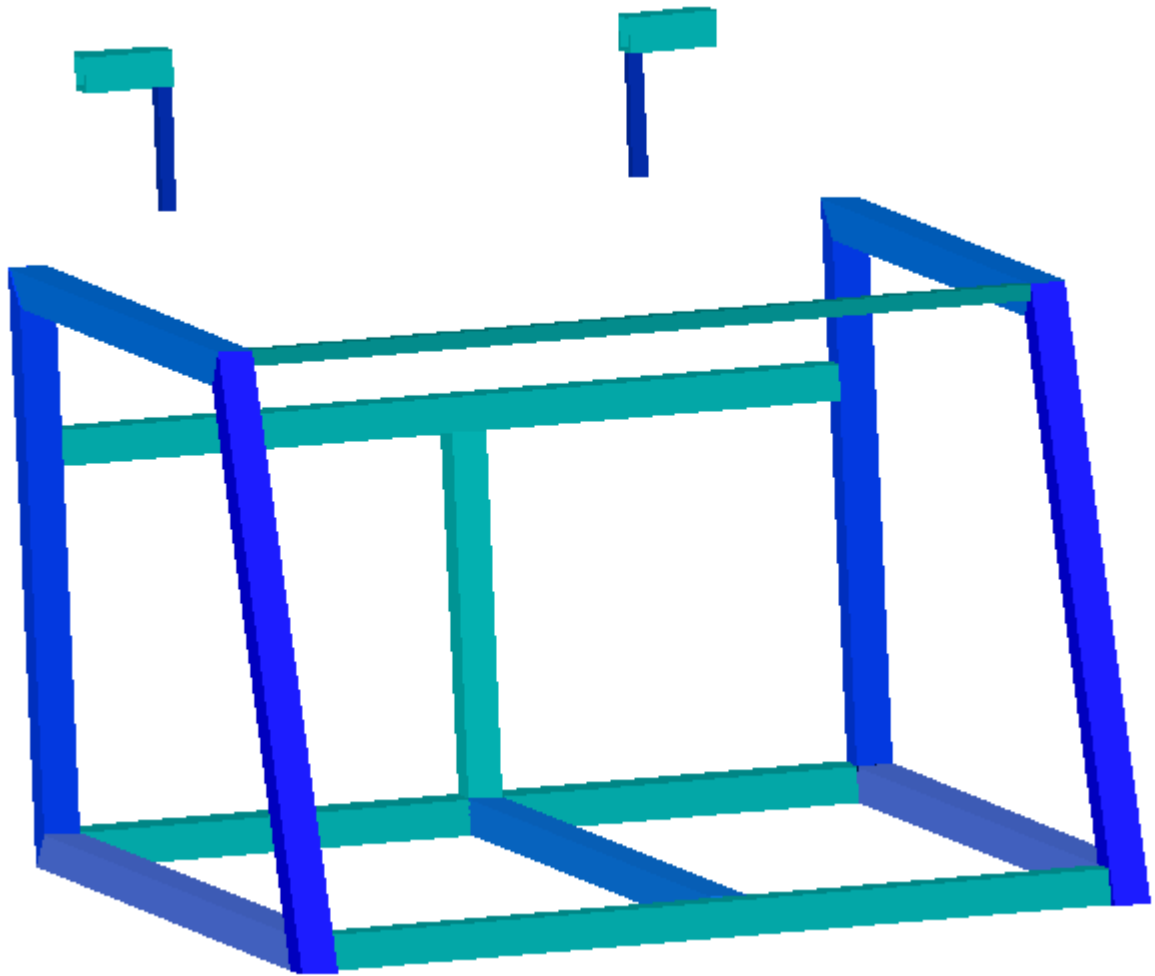

Step 13

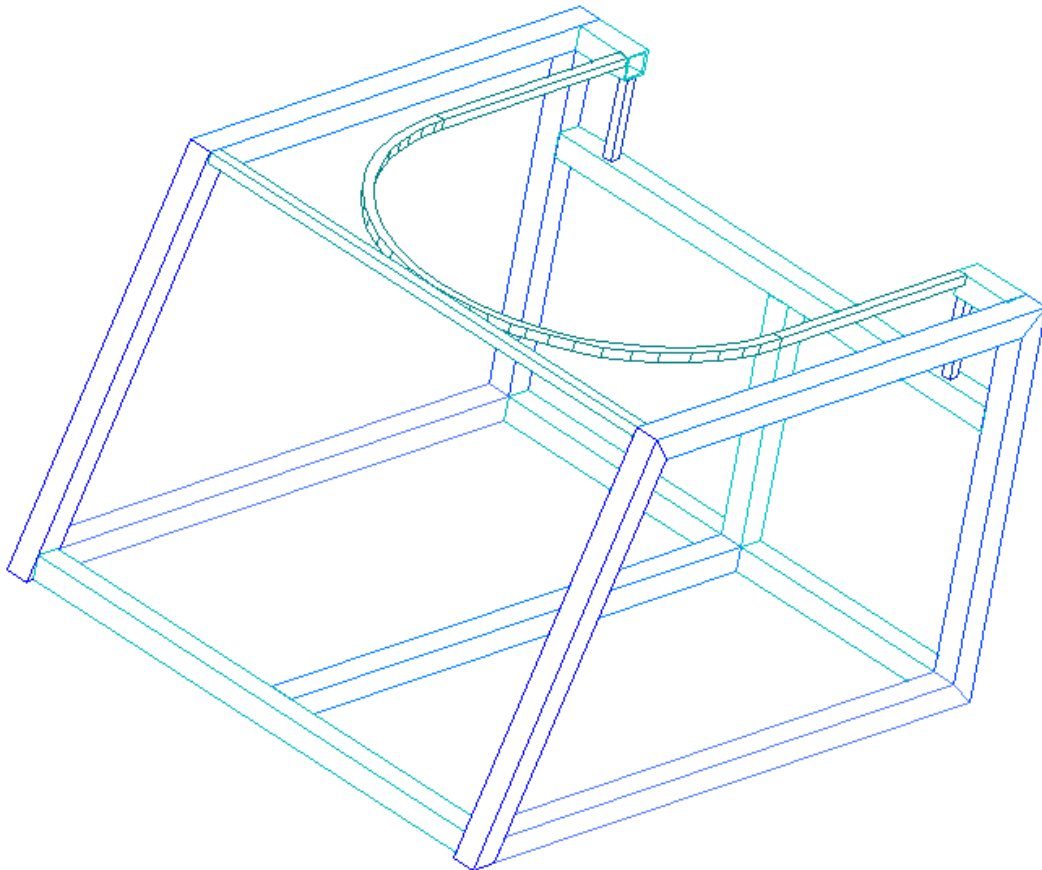
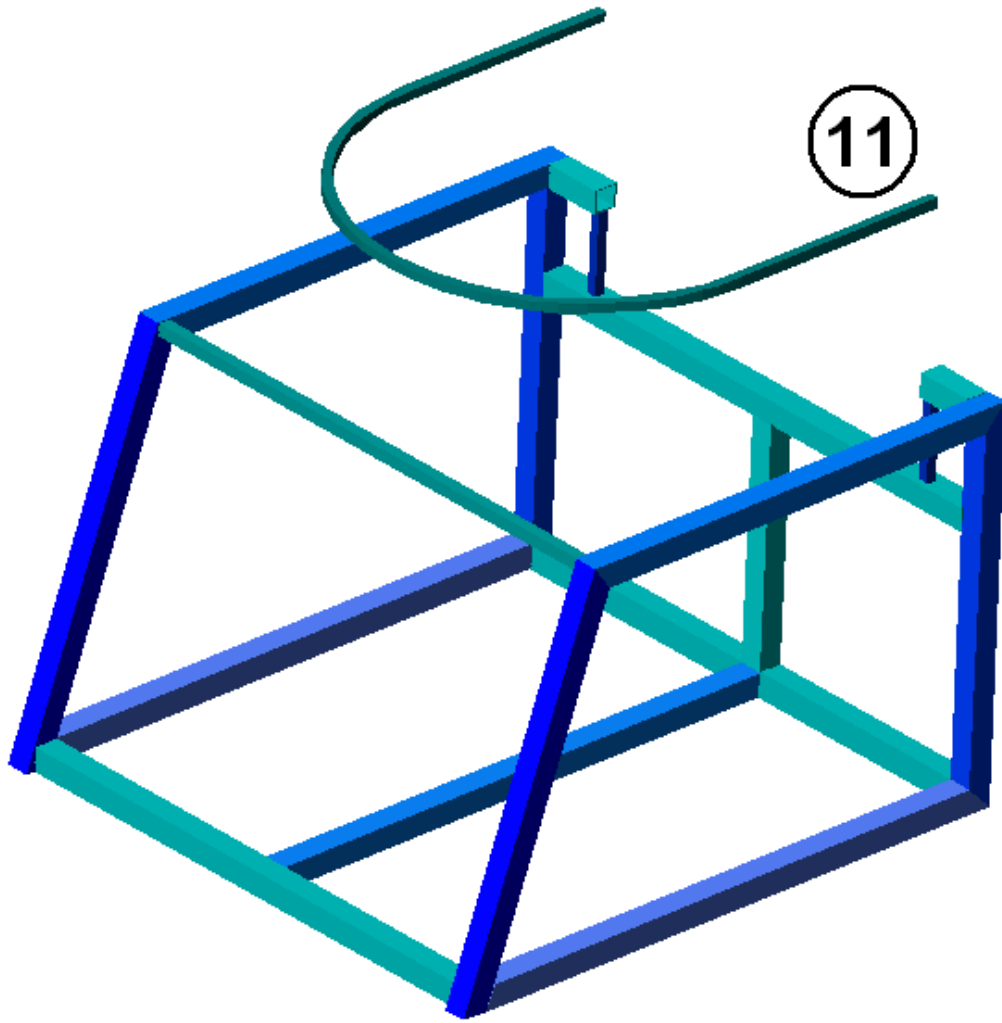

Step 14

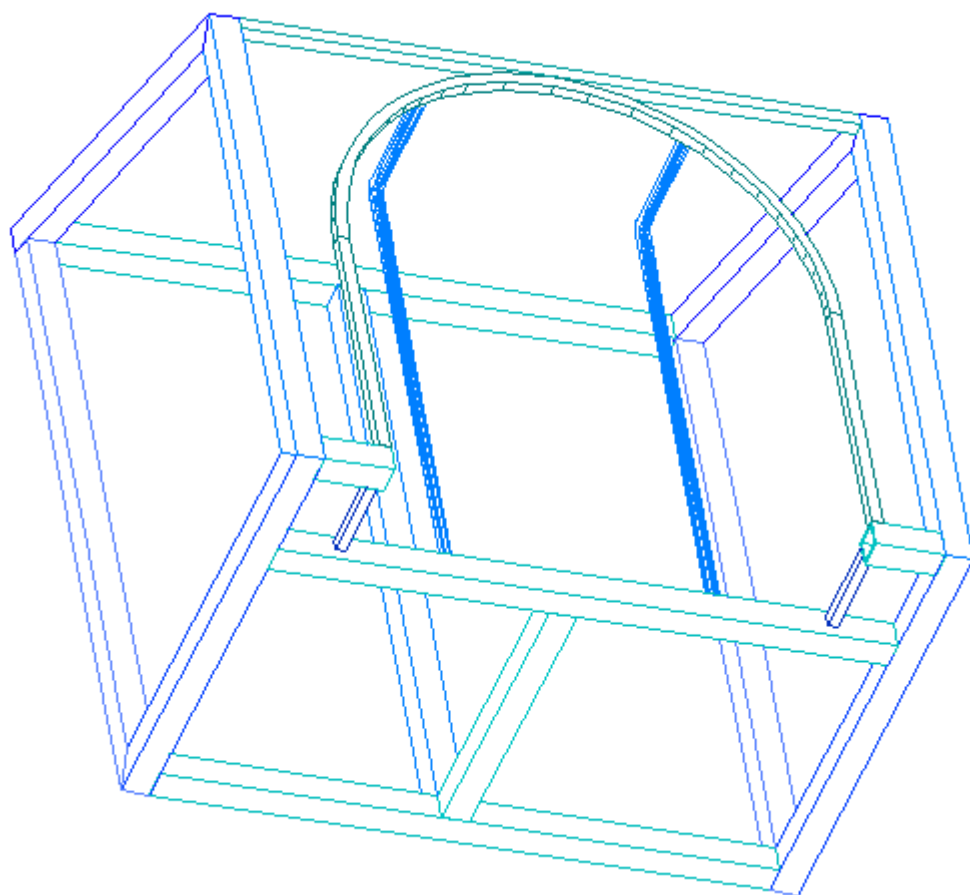
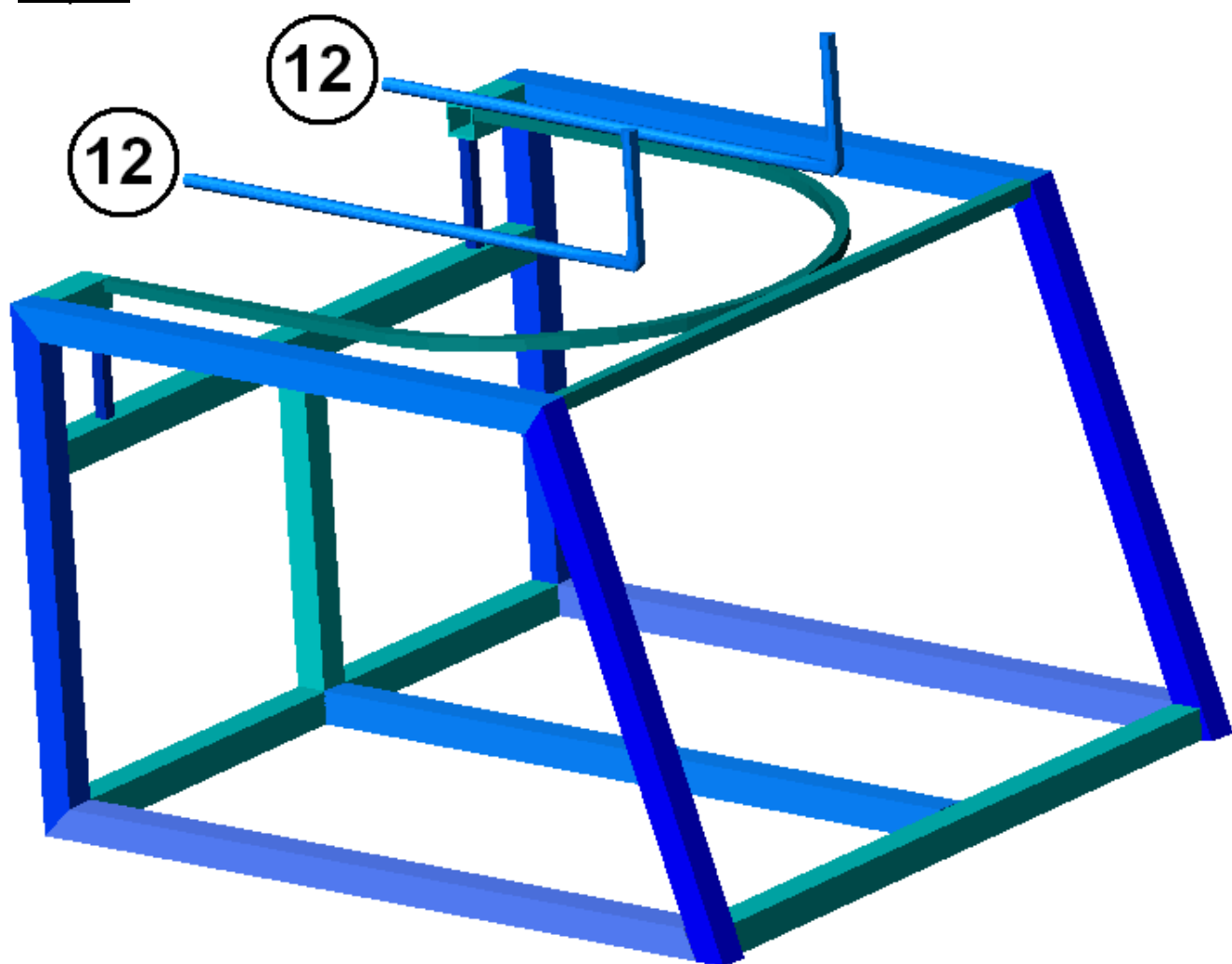

Step 15

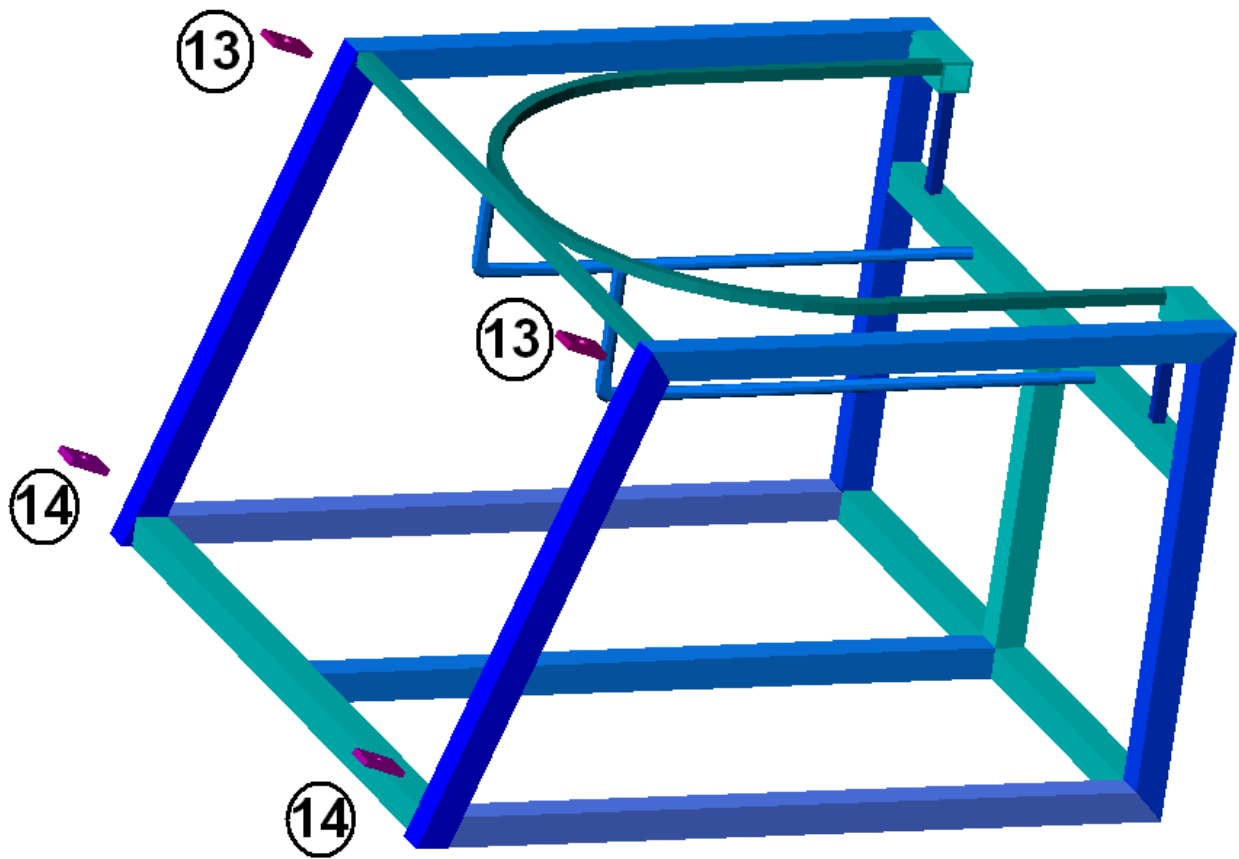

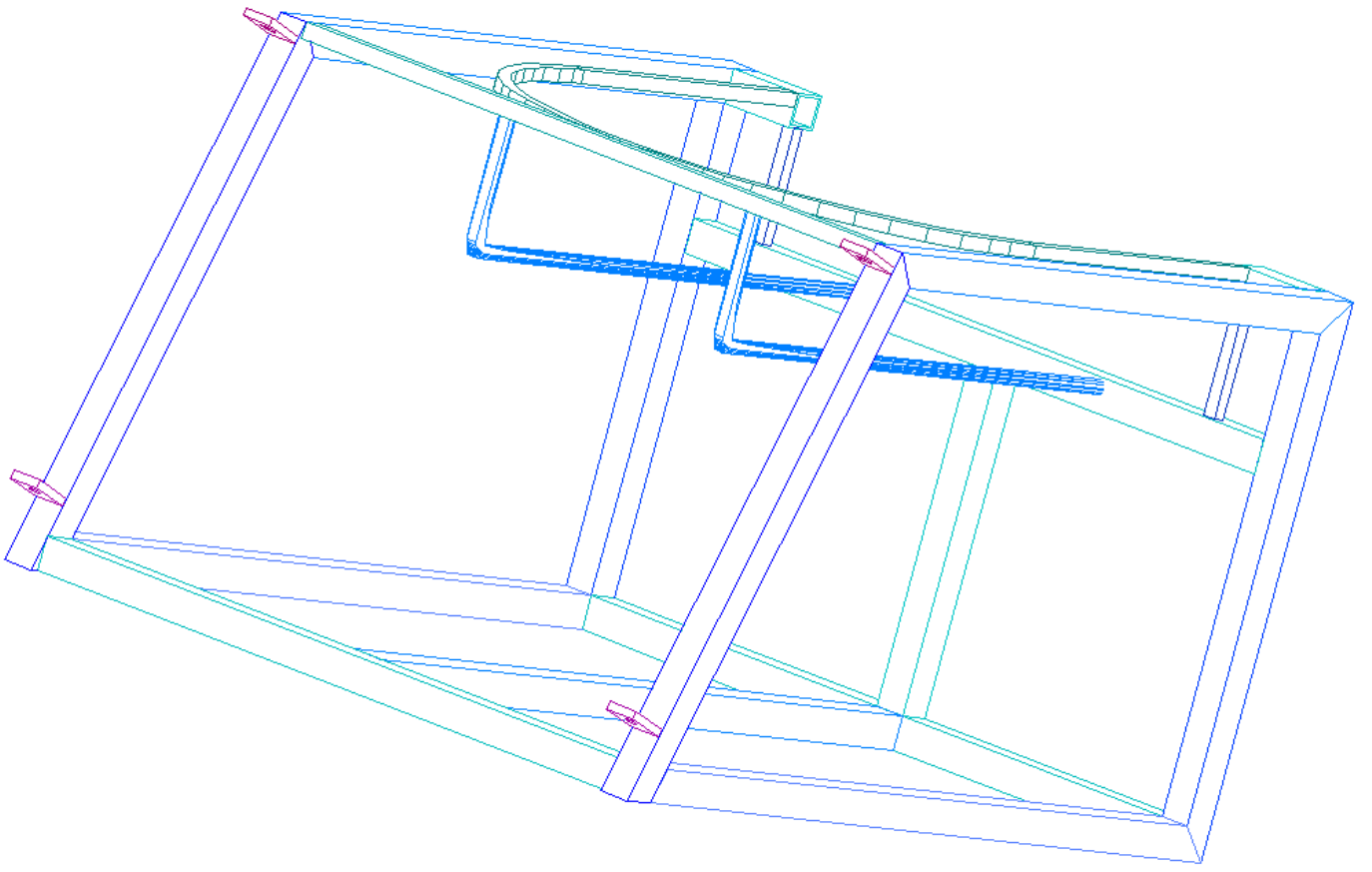

Step 16

apply primer

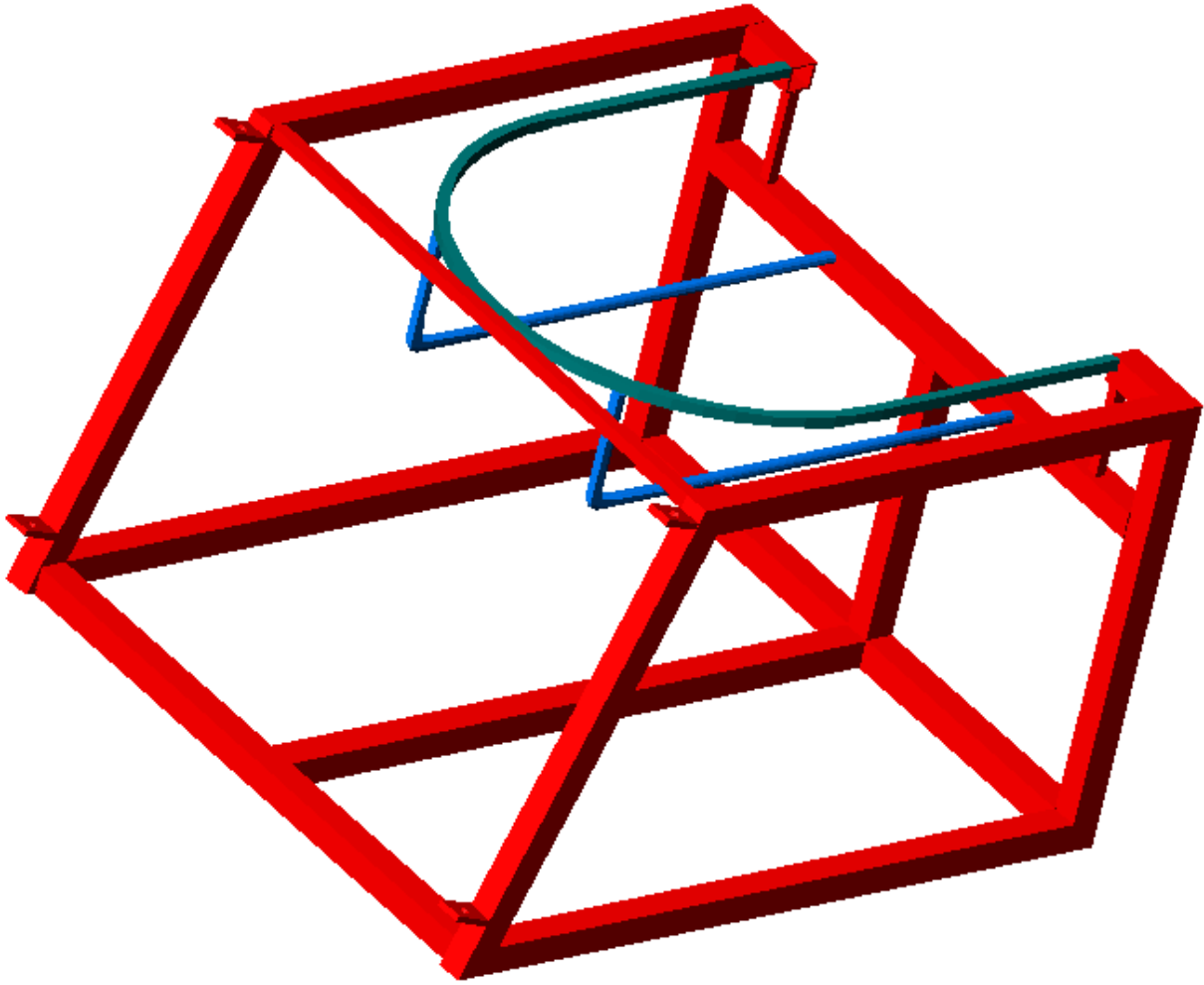

Step 17

Weld step 17 to step 20

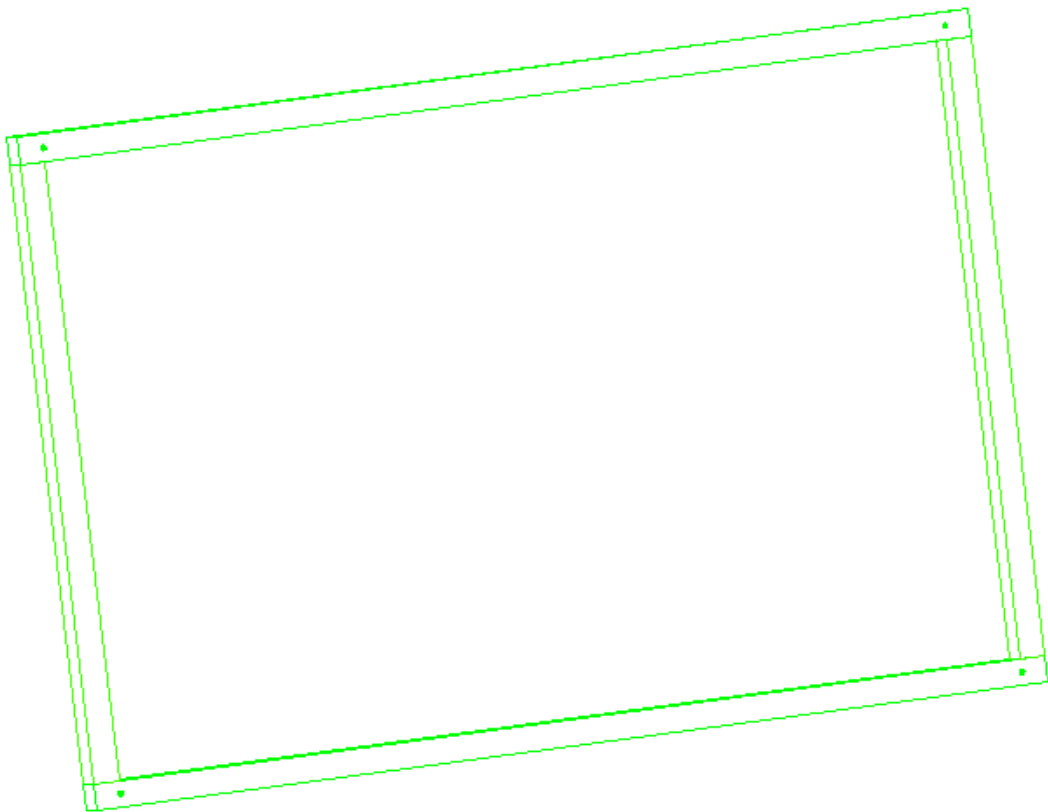
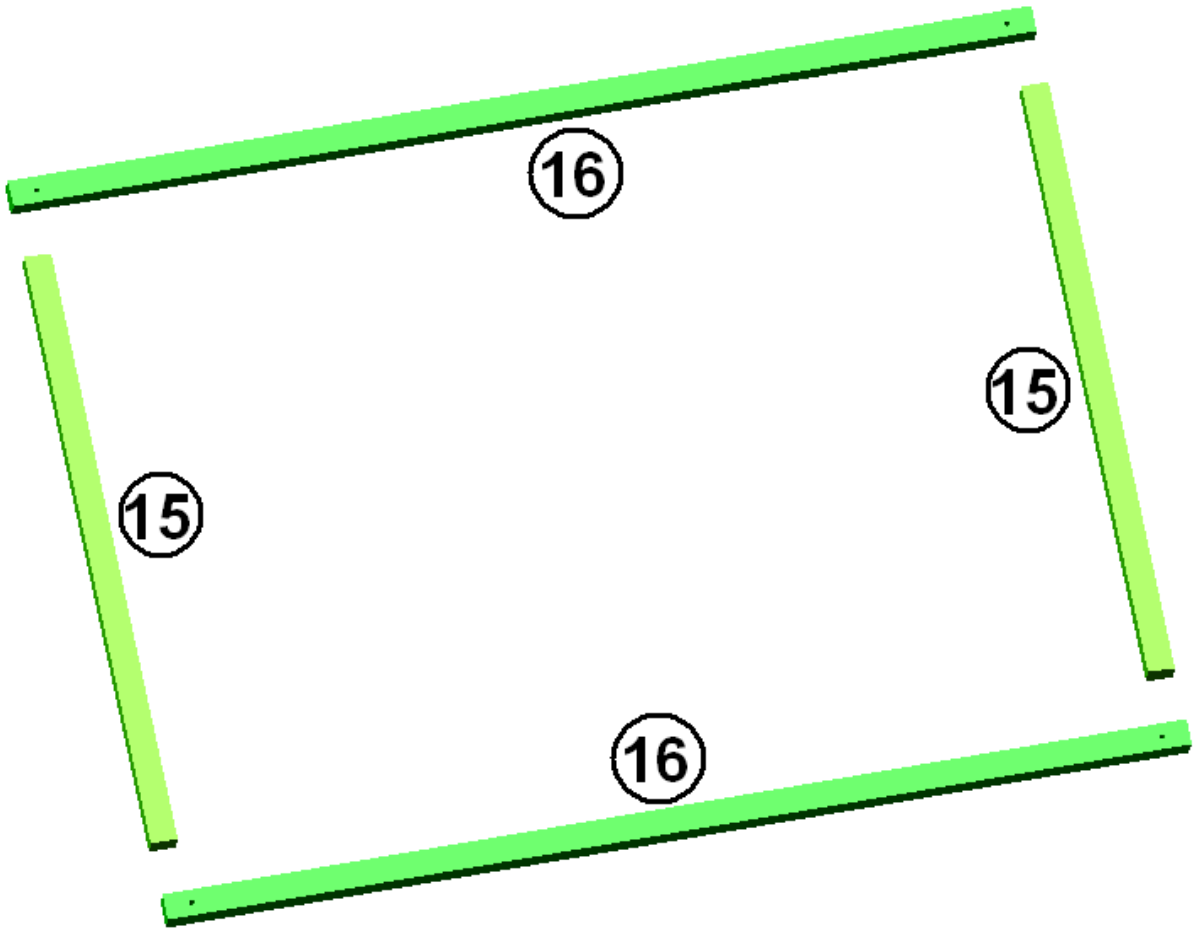

Step 18

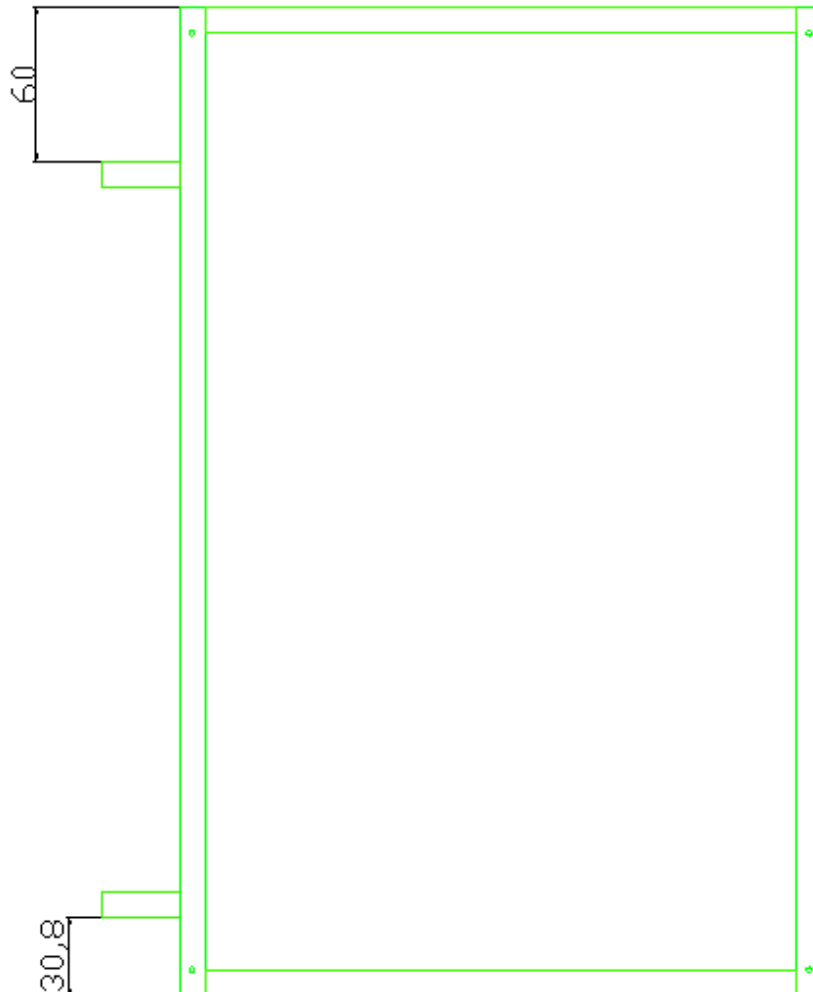
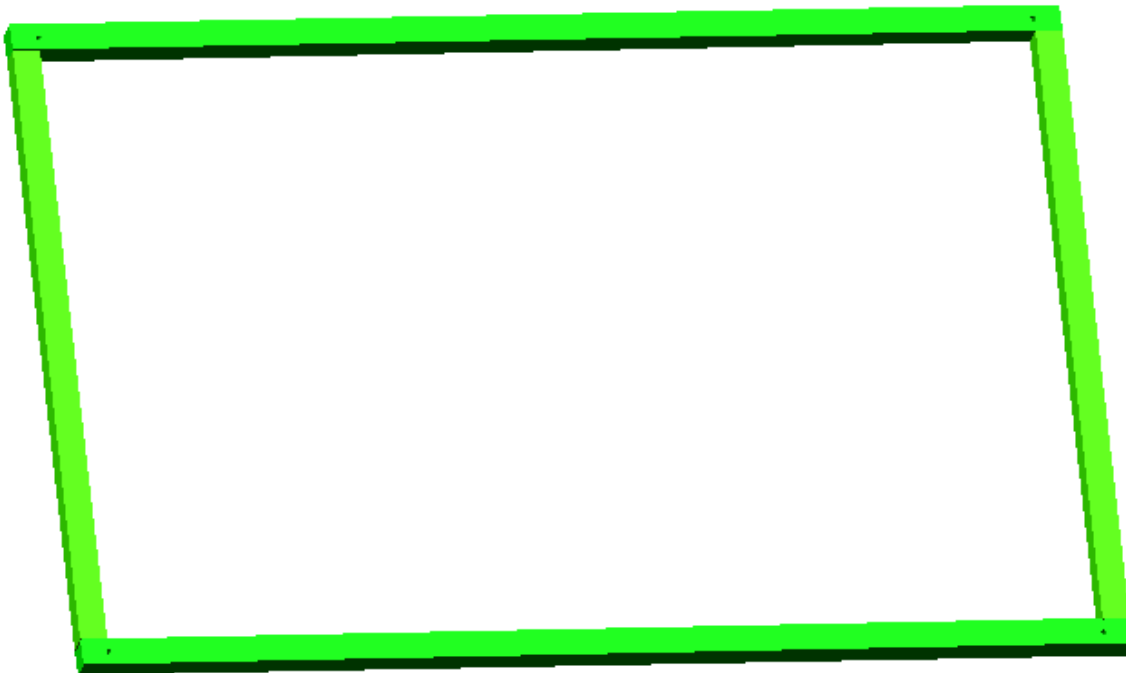

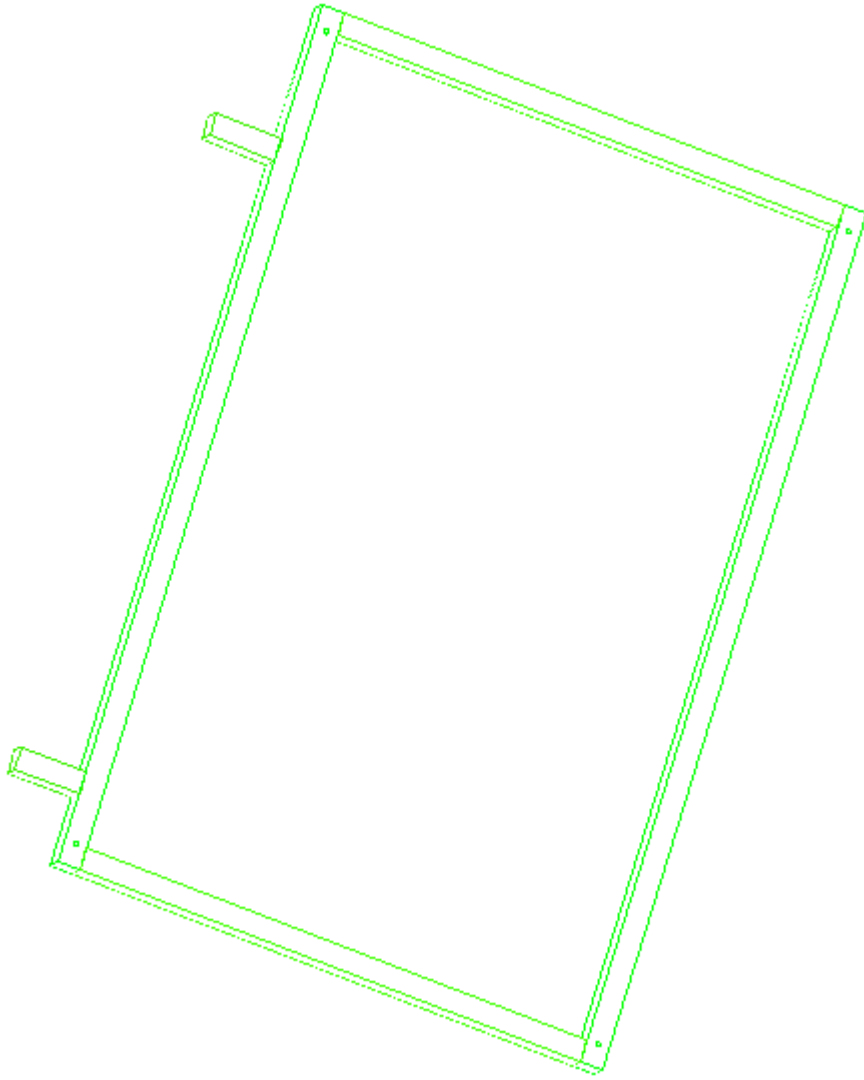

Step 19

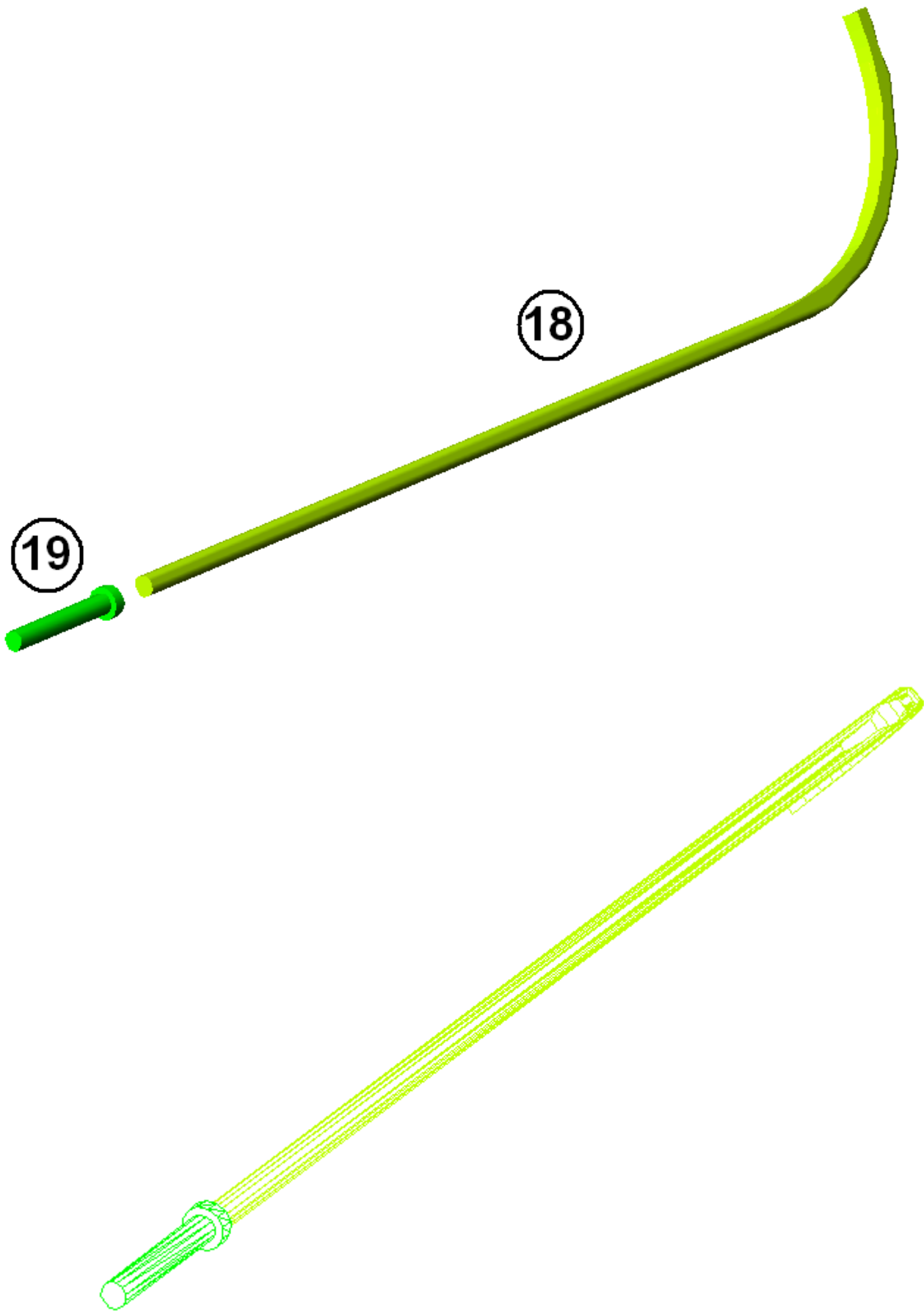

Step 20

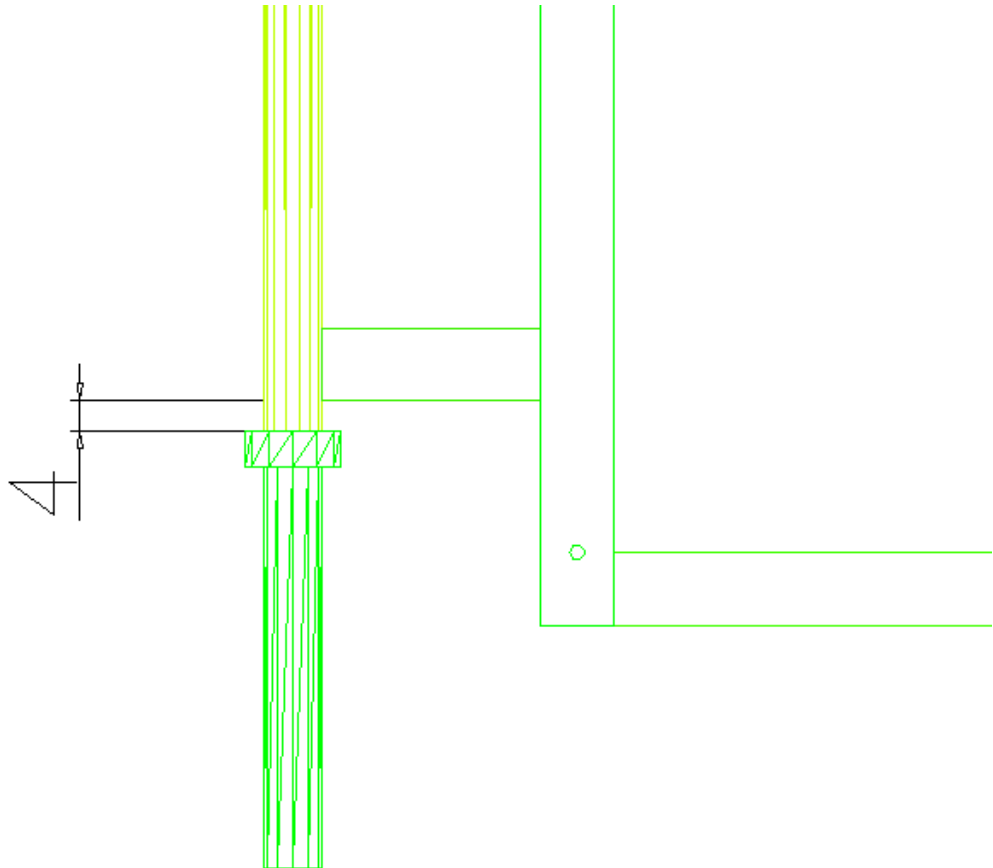
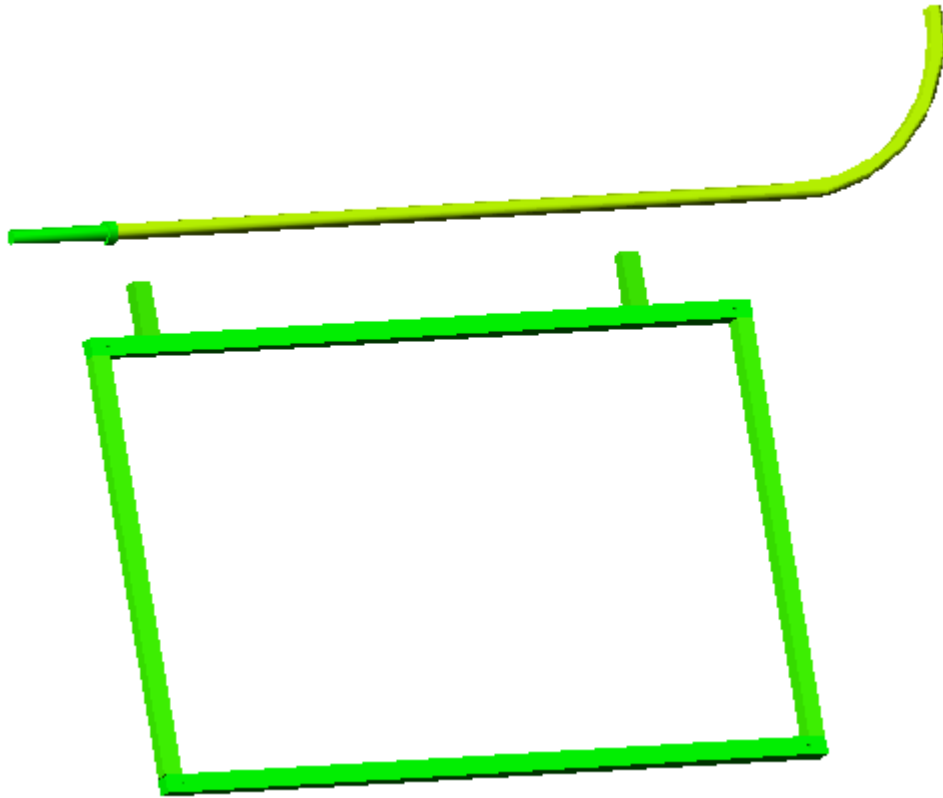

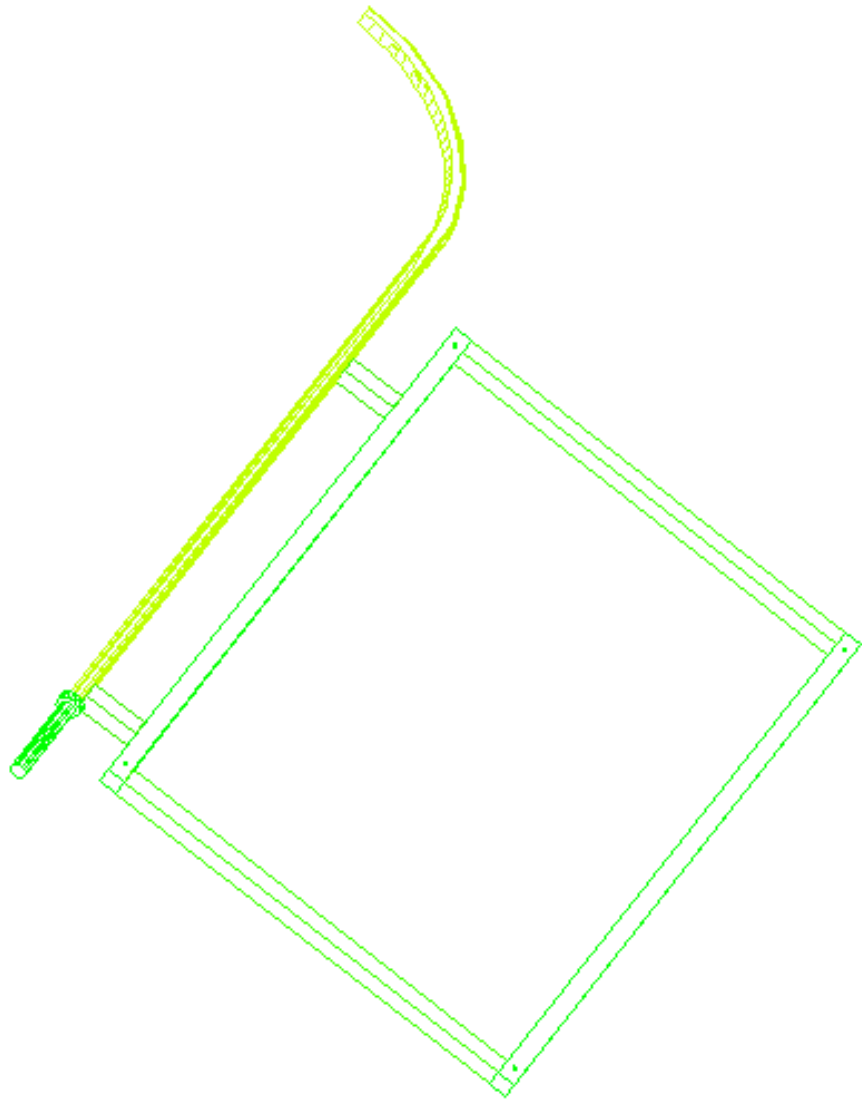

Step 21

paint

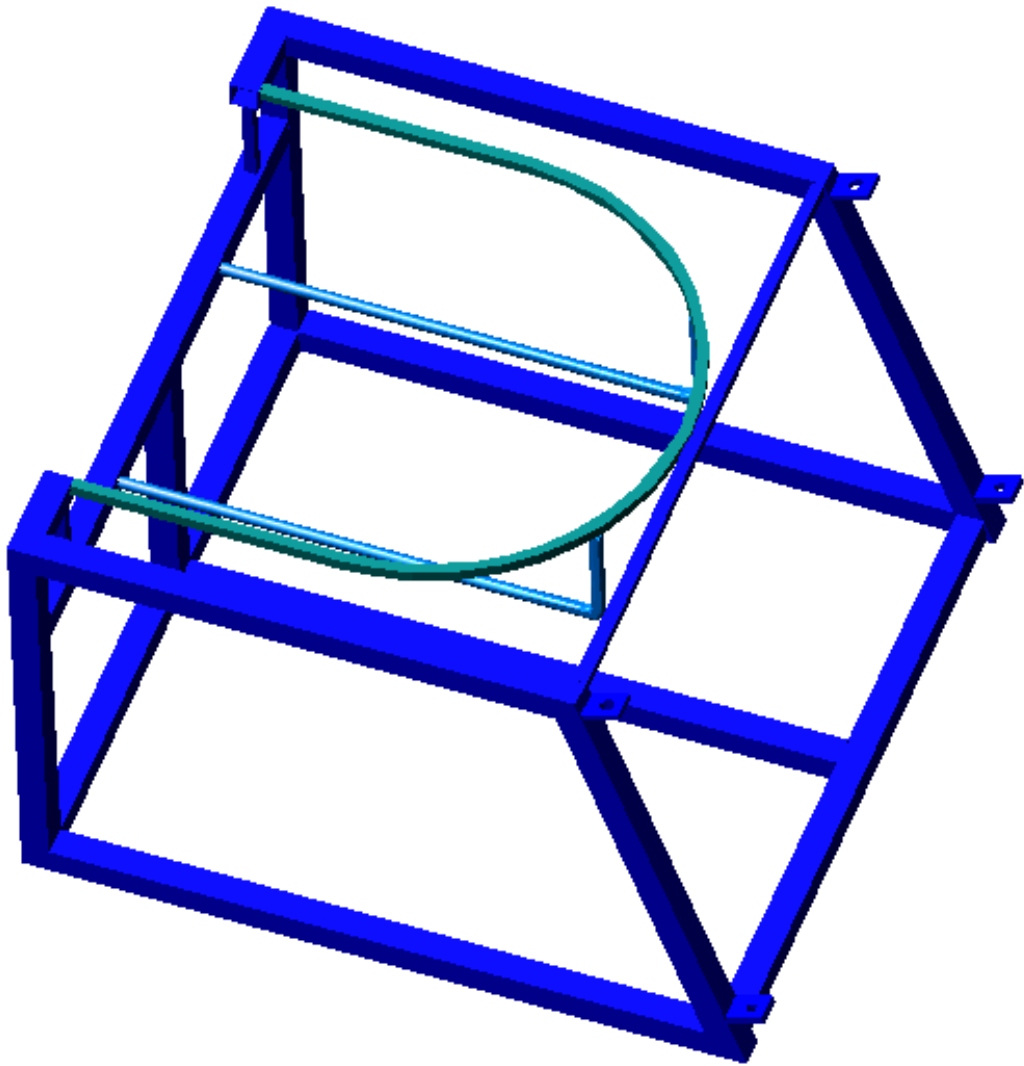

Step 22

Rivet central support for secondary reflector to frame

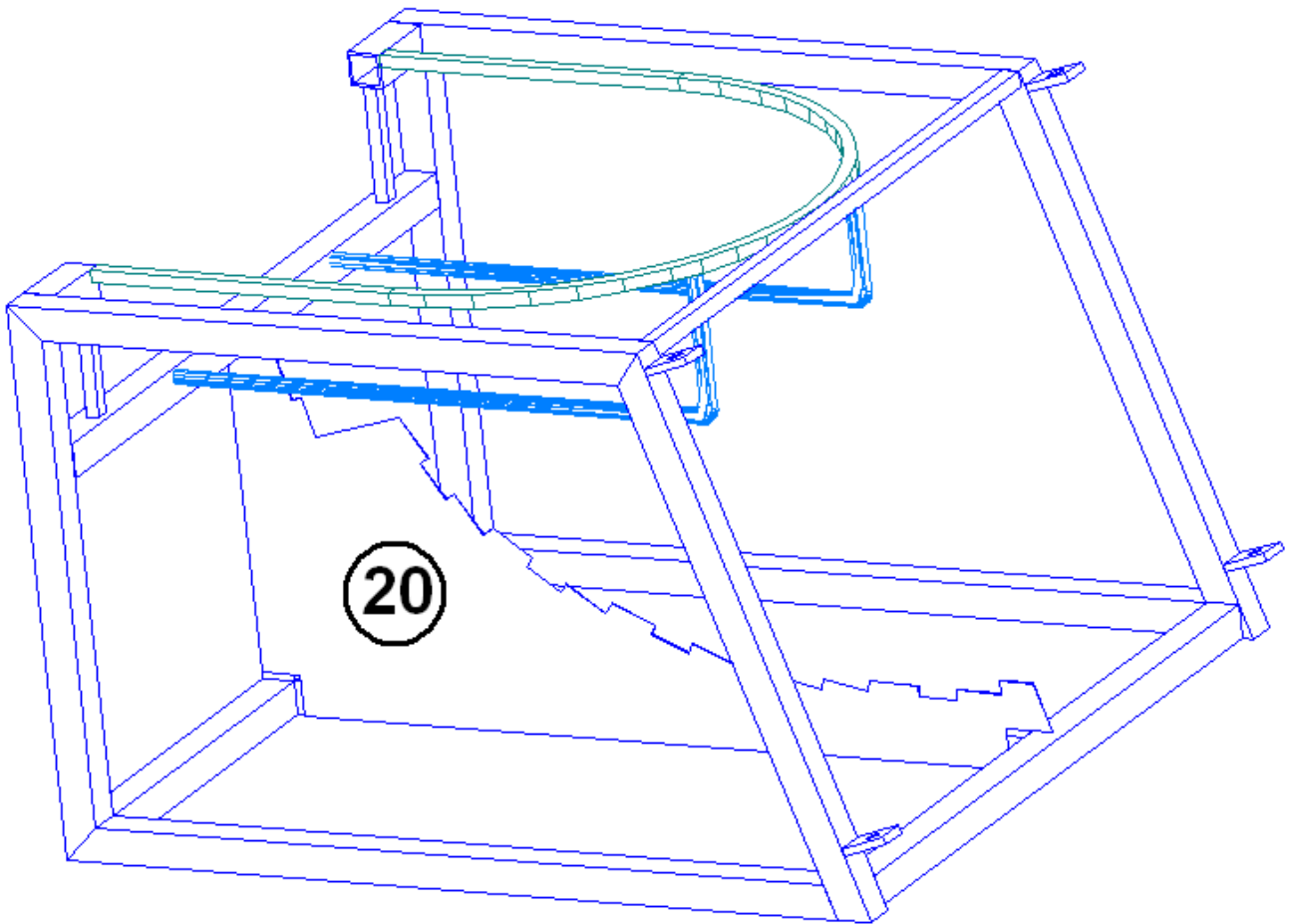

Step 23

Rivet lateral support for secondary reflector to frame

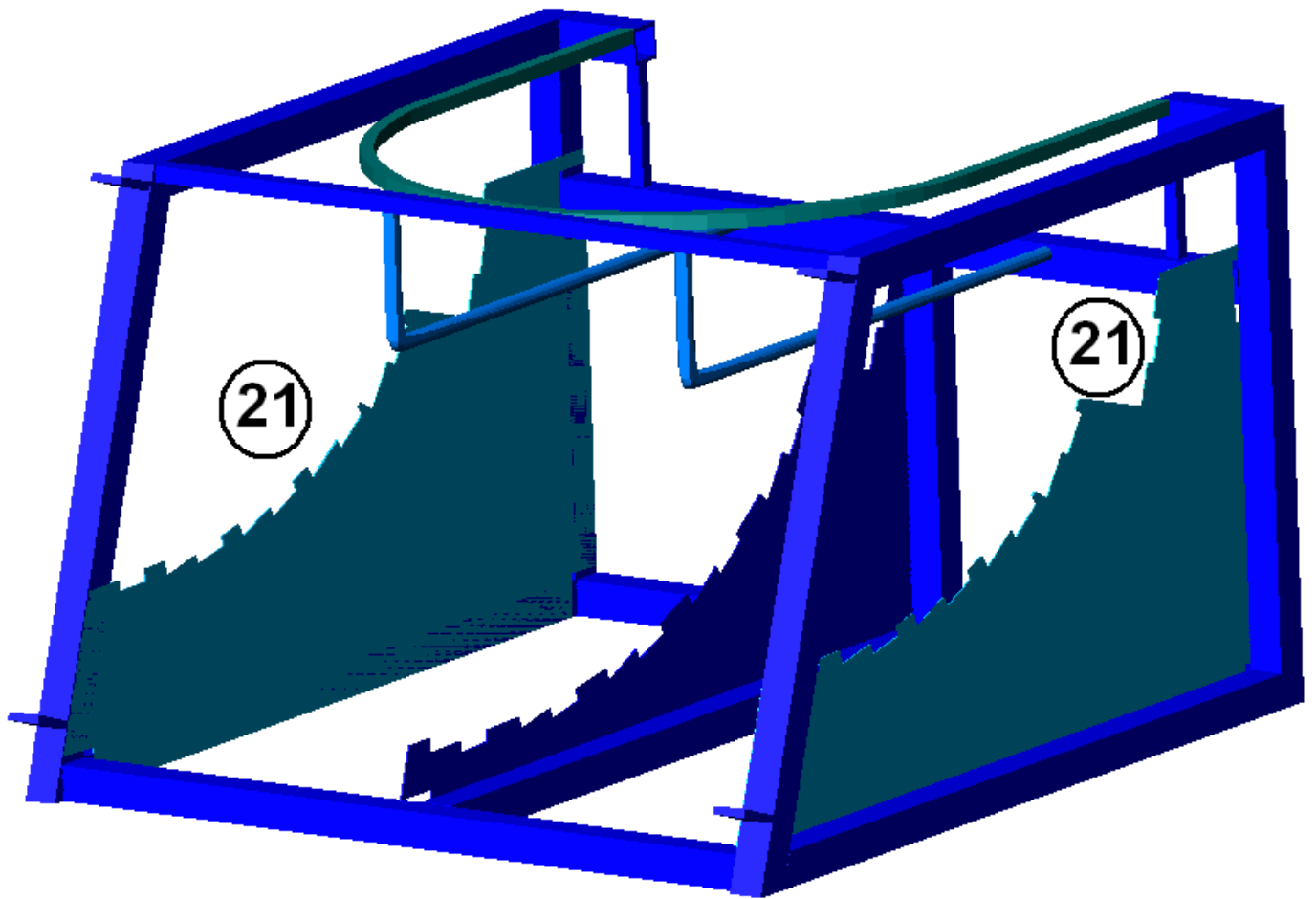

Step 24

Rivet covers form outside onto the frame

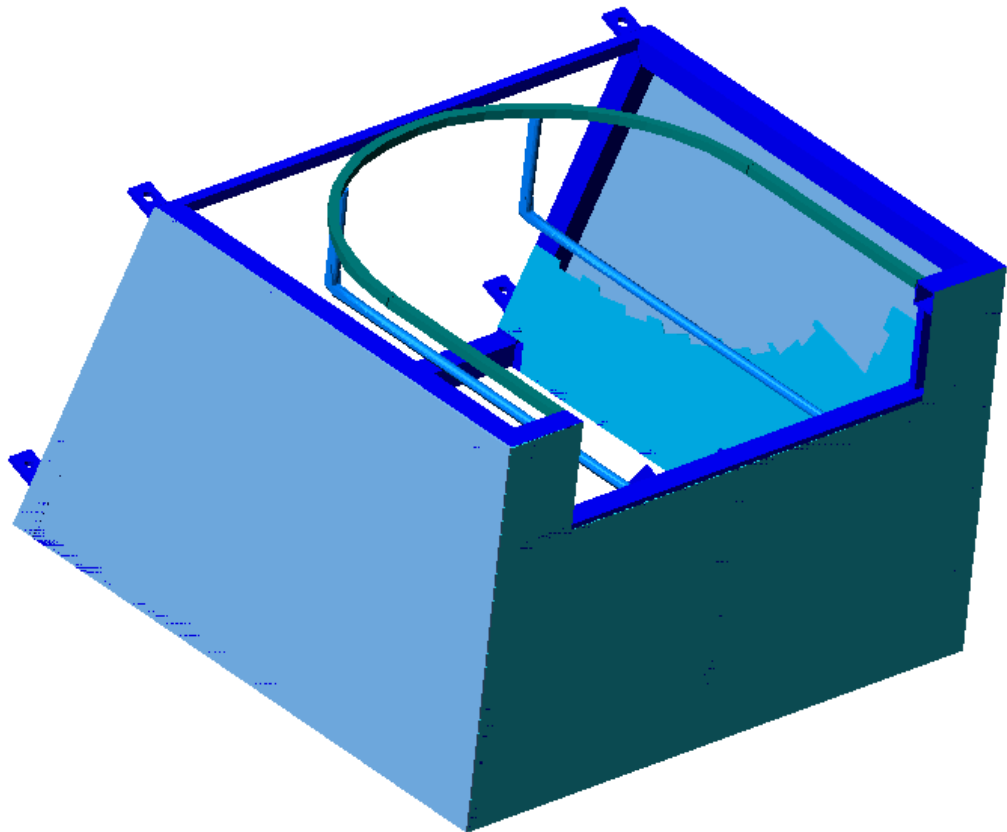
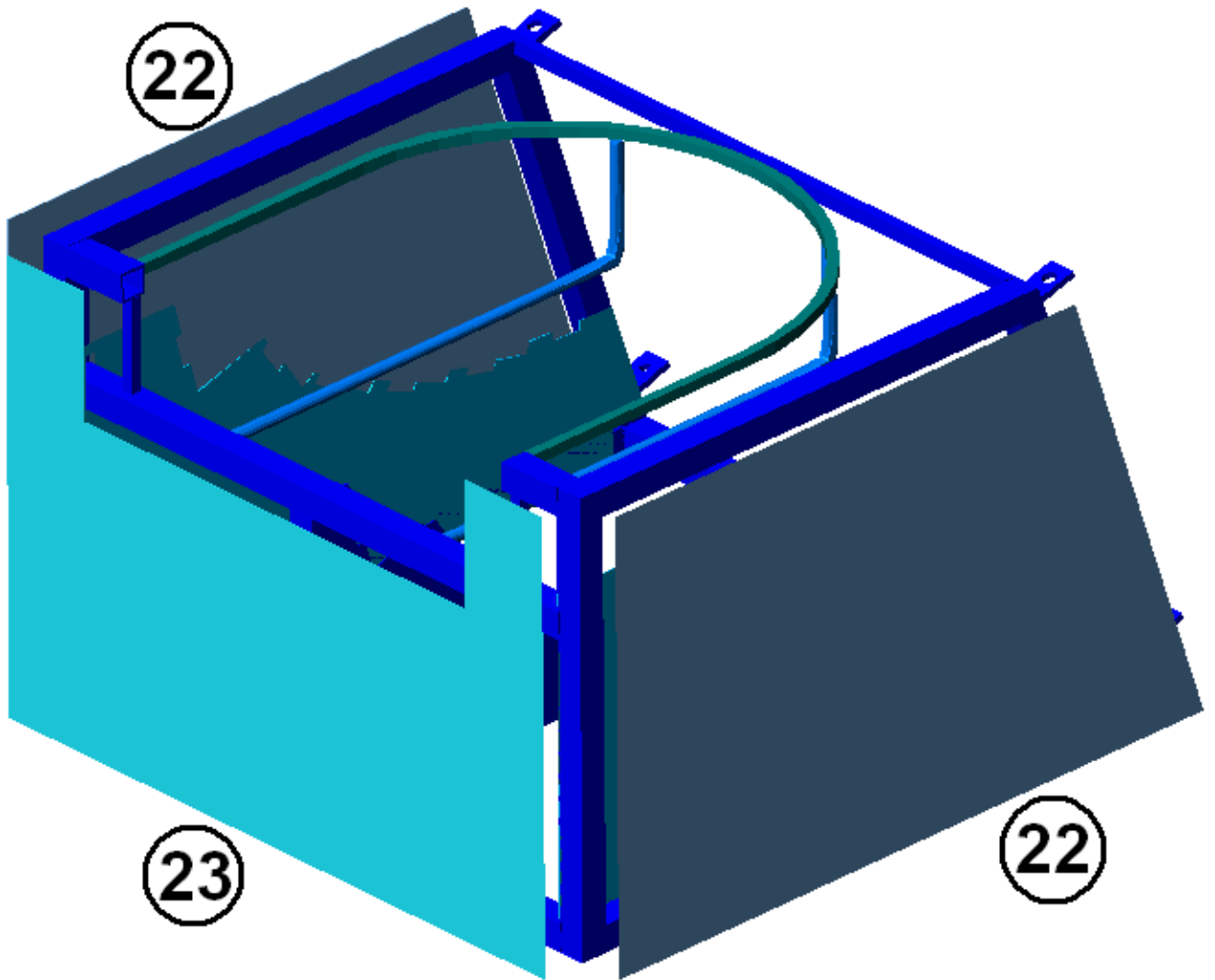

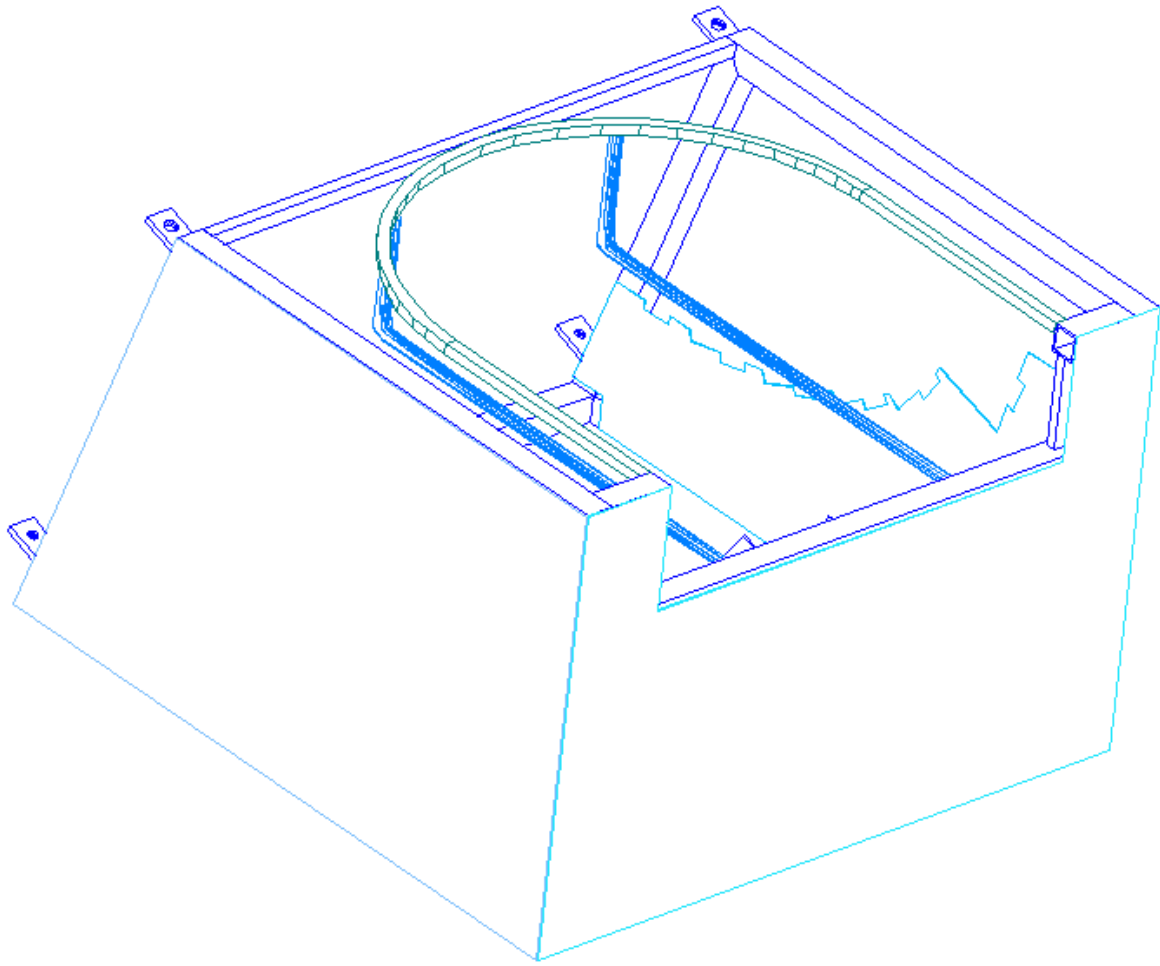

step 25

rivet top cover onto frame

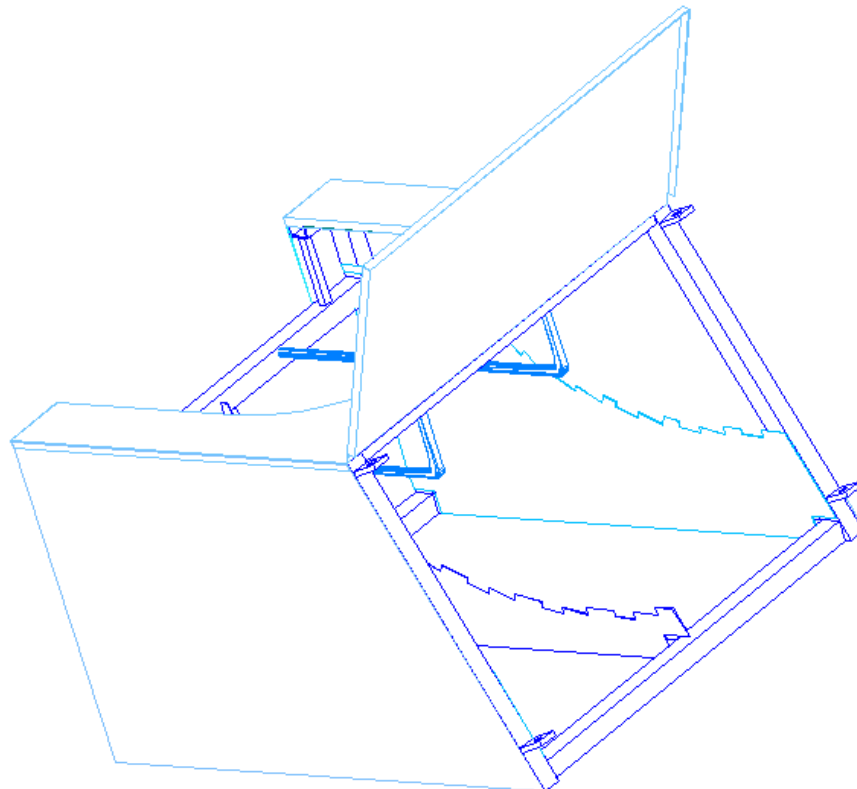
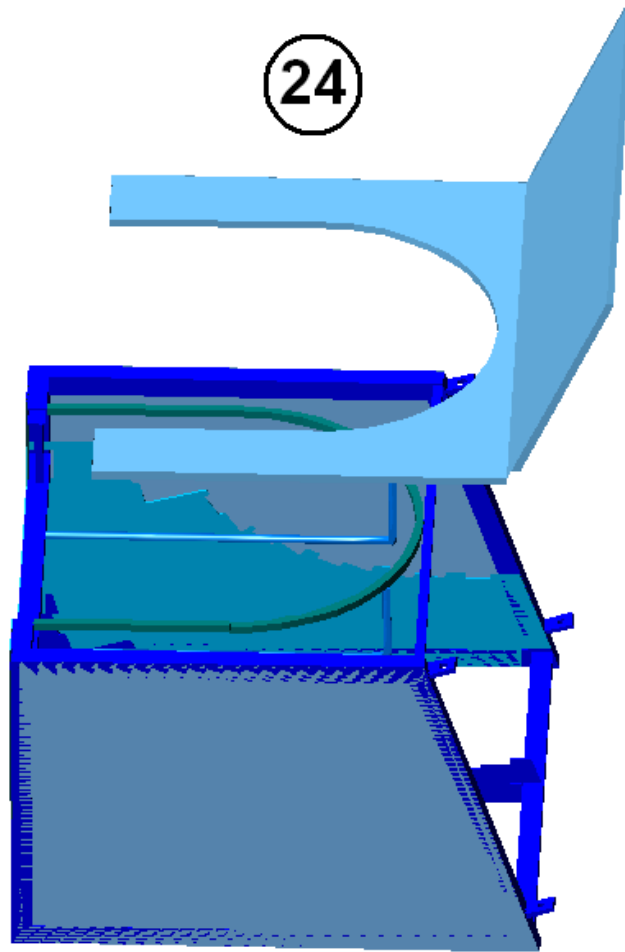

step 26

bolt together

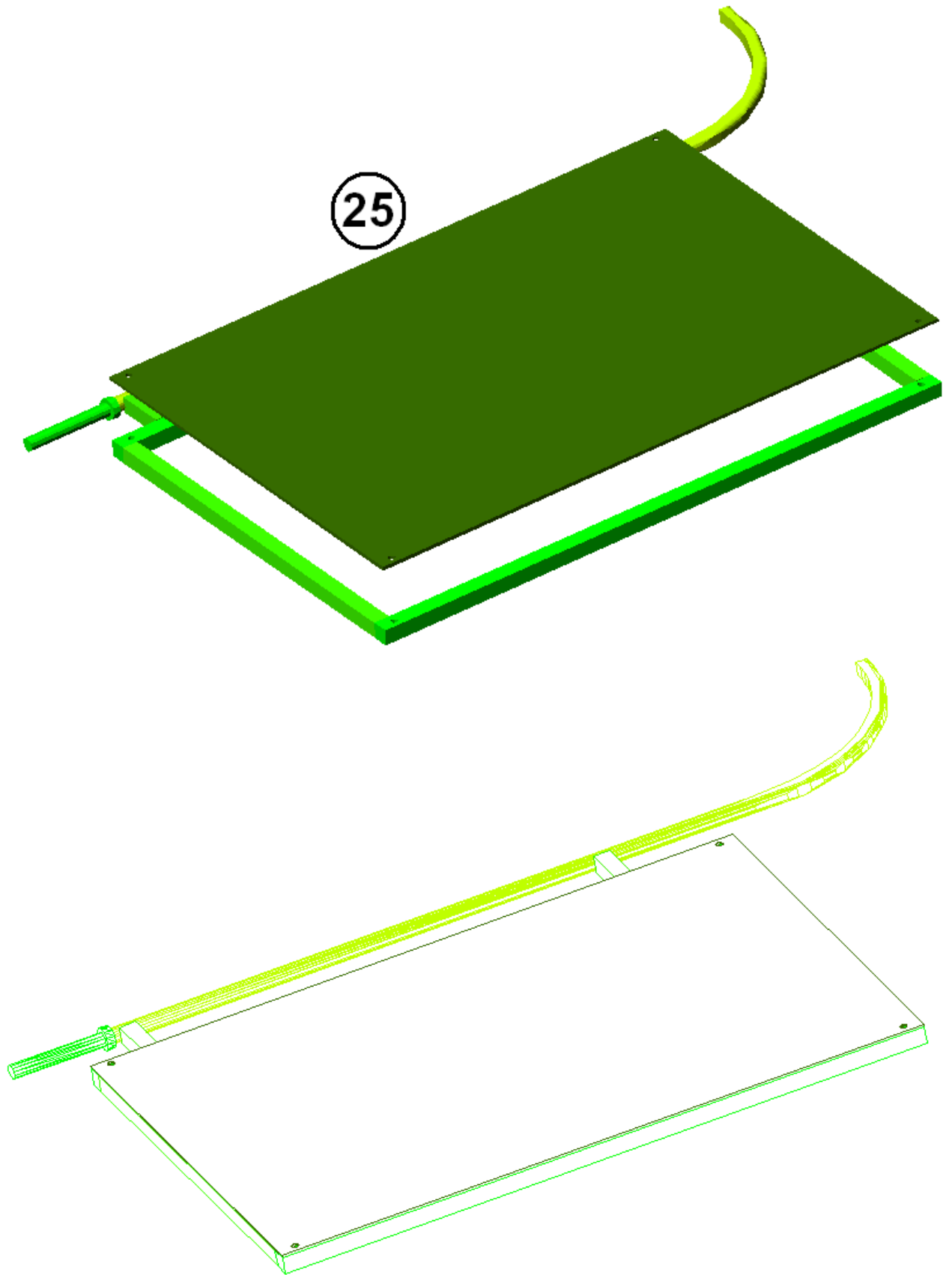

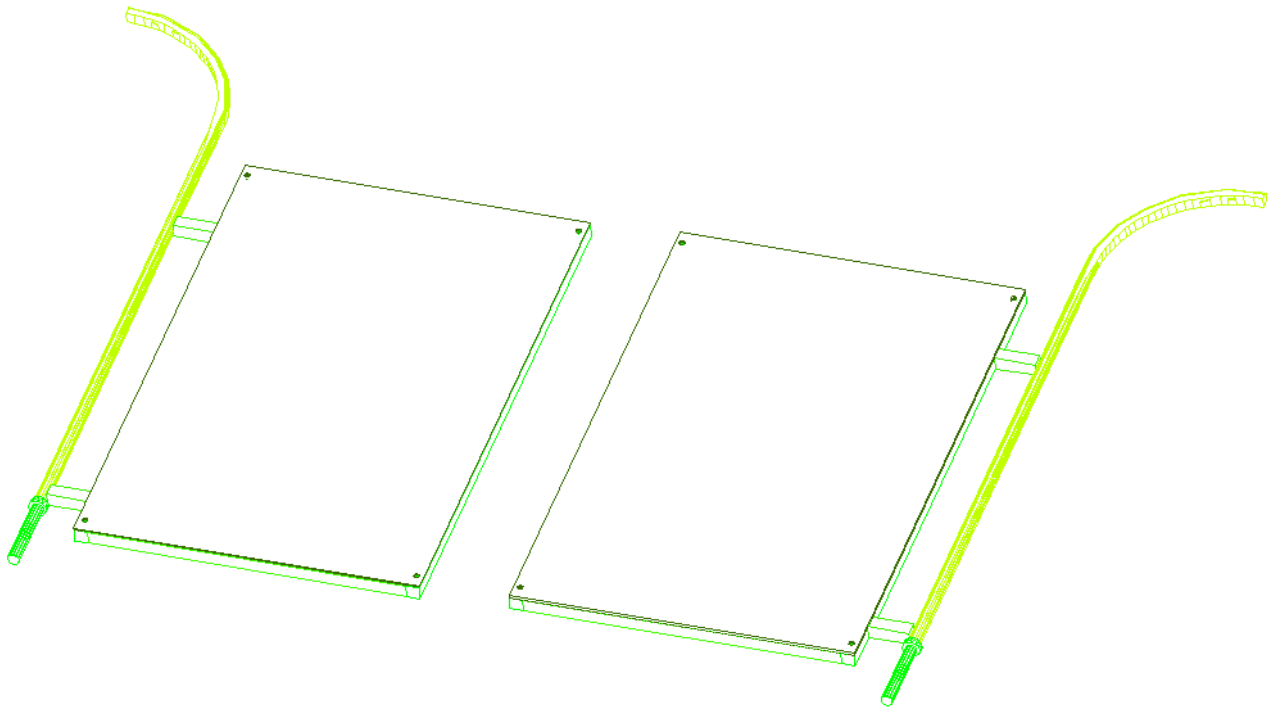

step 27

first drill two holes with 24mm diameter and then insert the doors

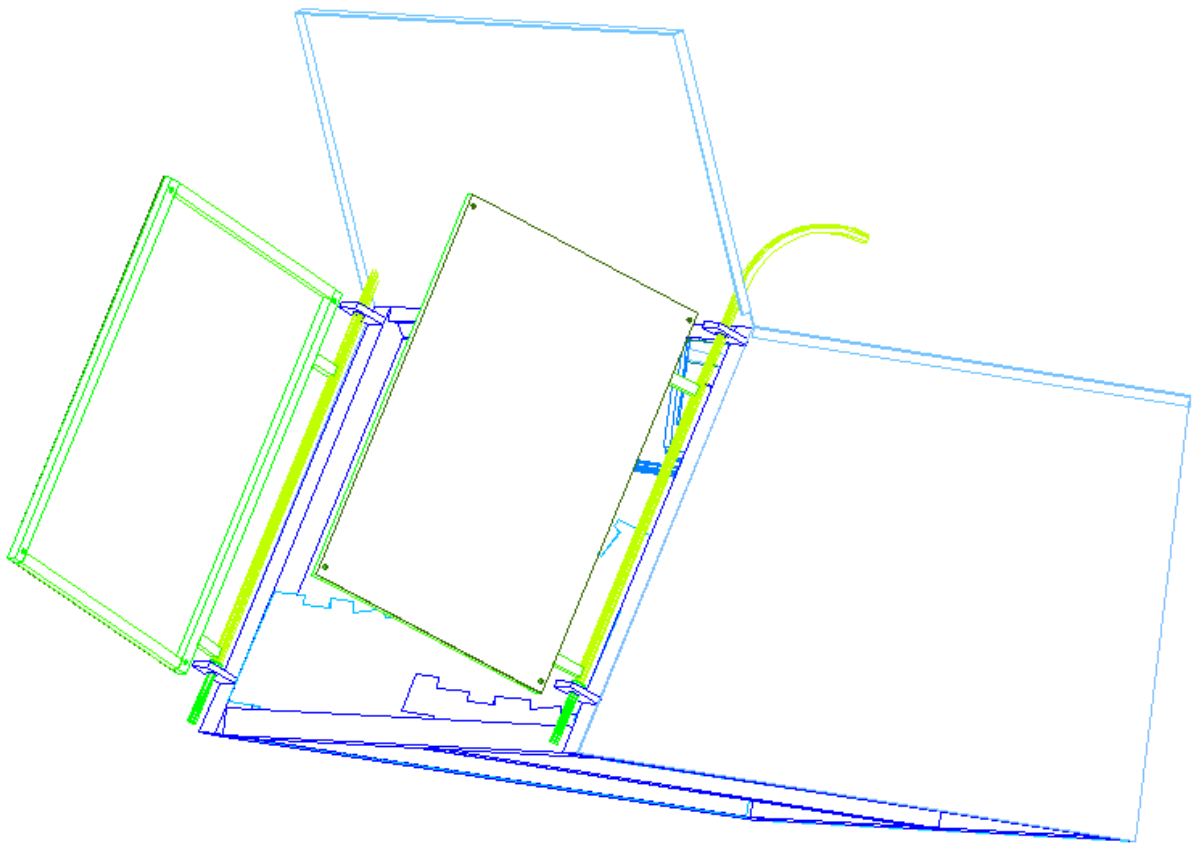
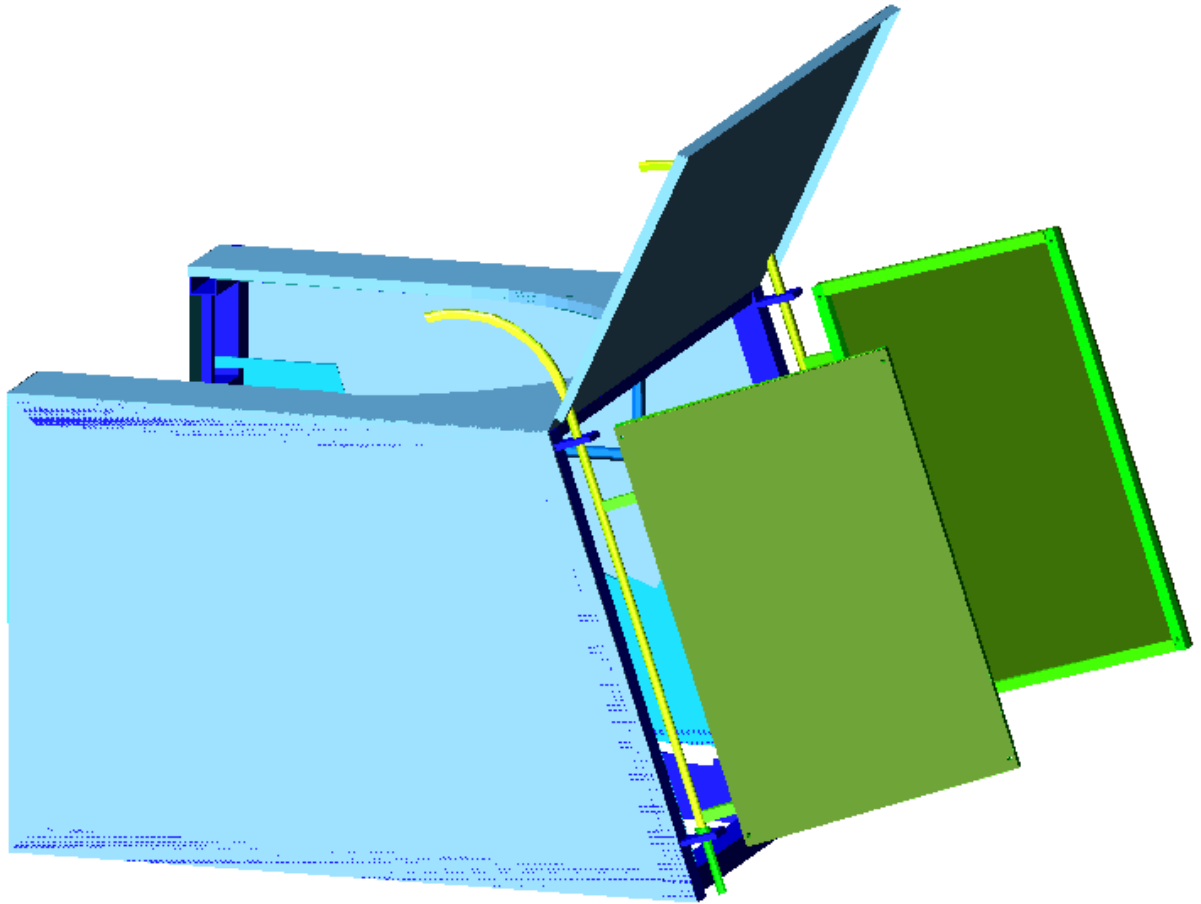

step 28

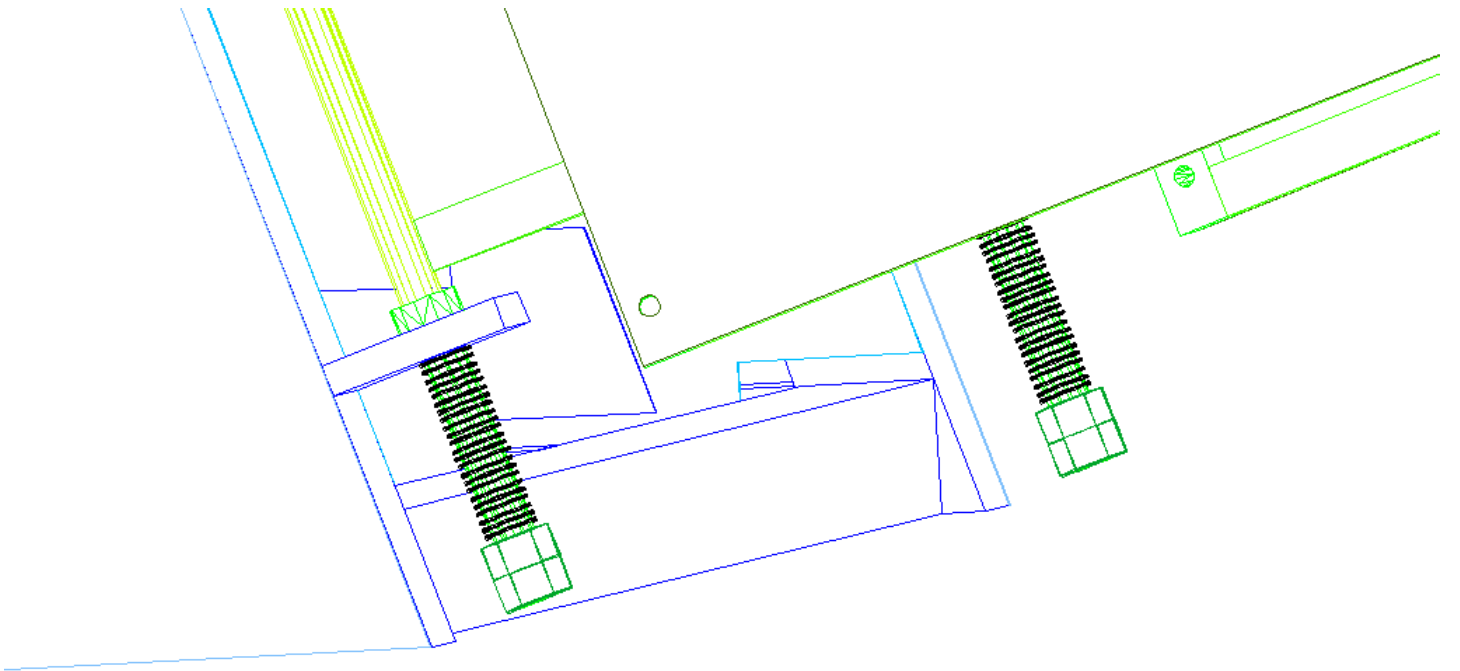
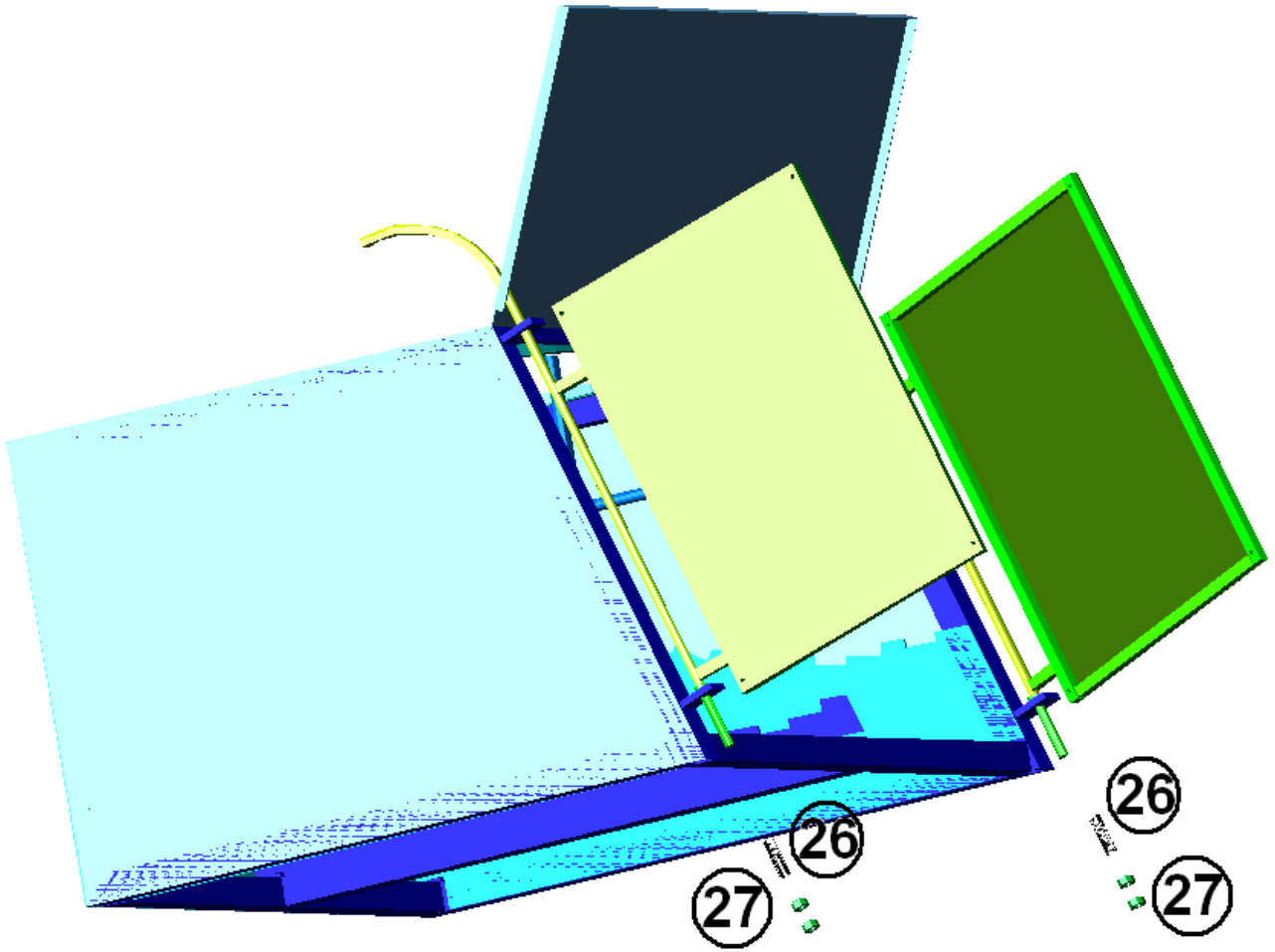

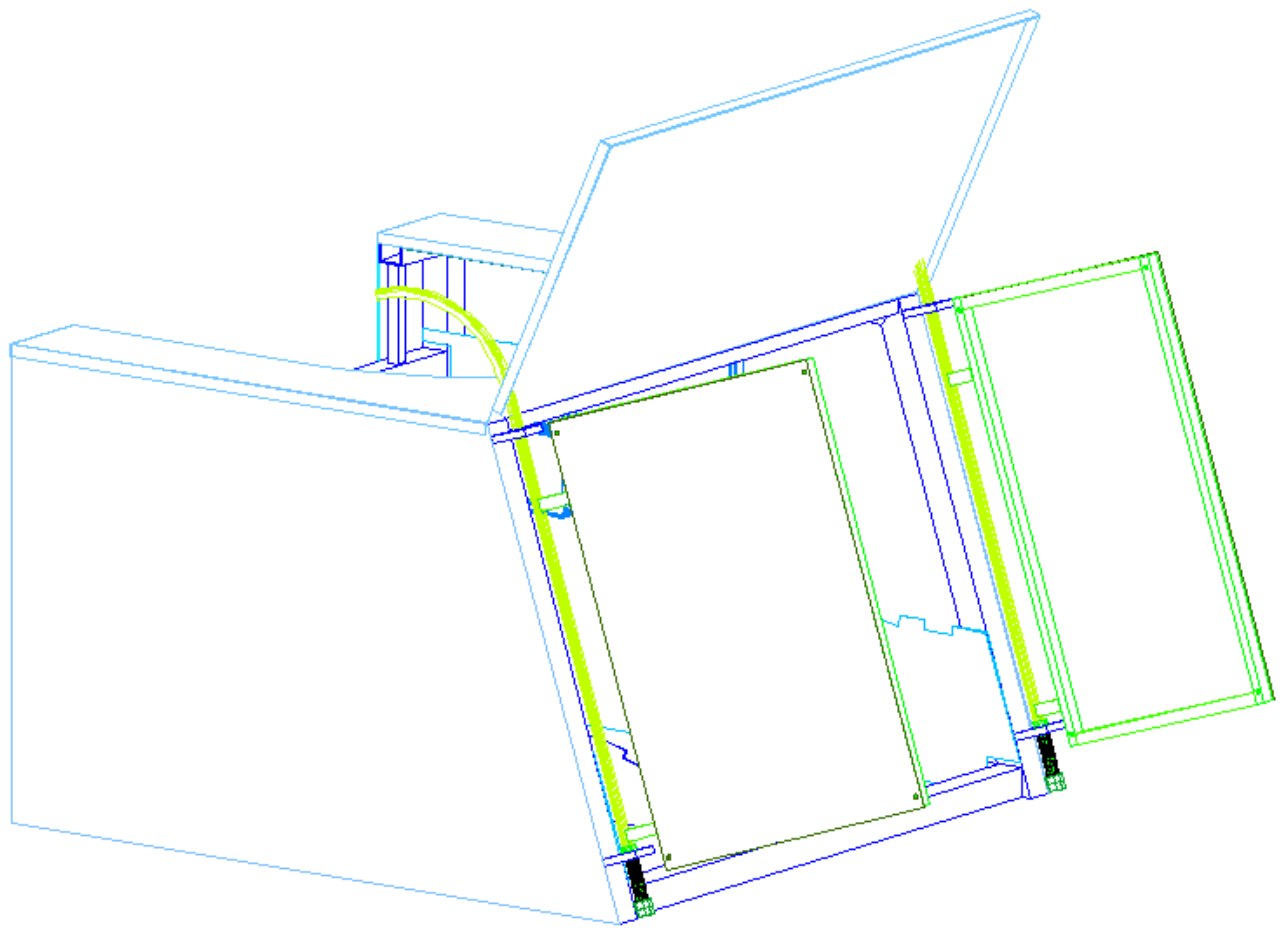

step 29

use wire to fix part 29 on part 28

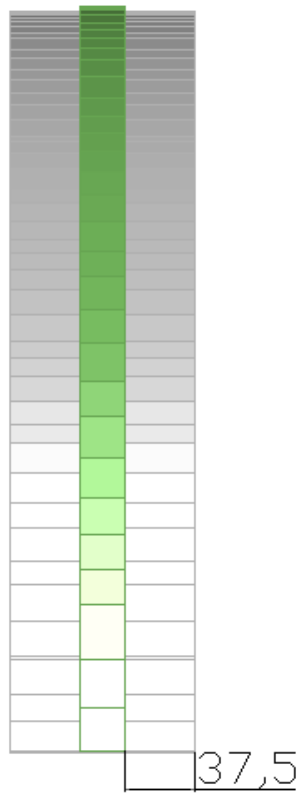
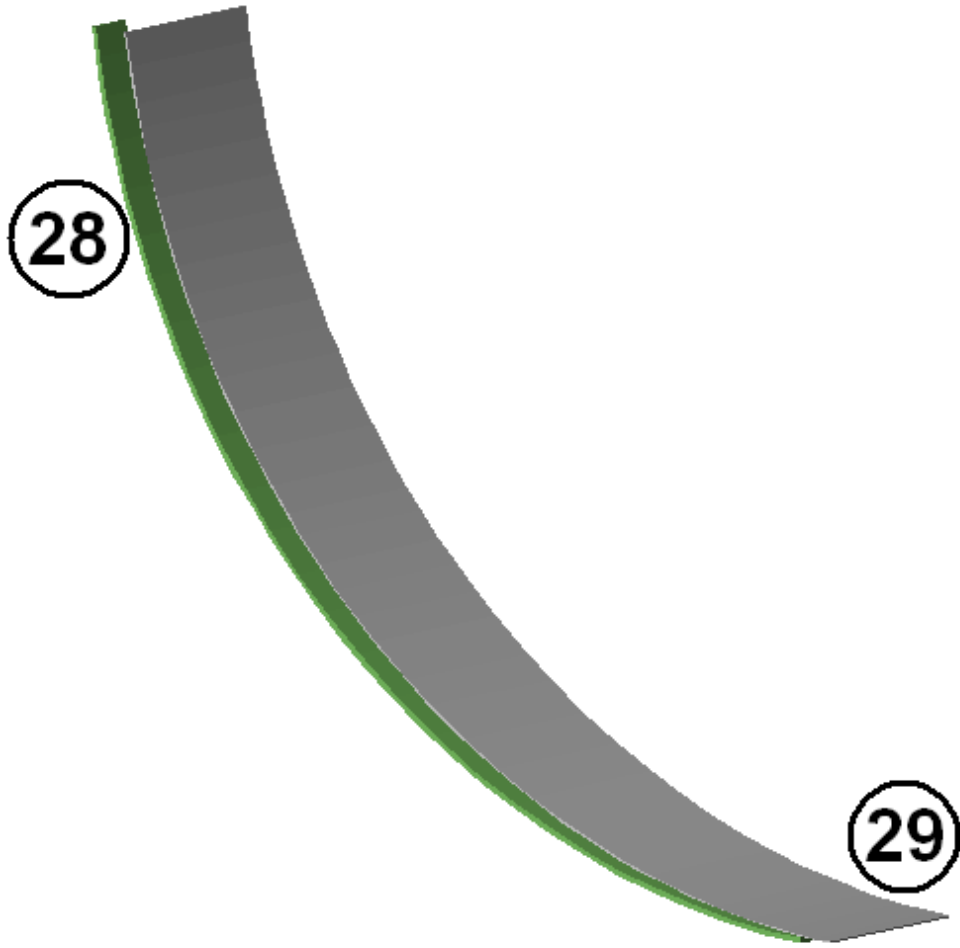

step 30

